

Measure

Instructions for Use

Auditdata

Copyright notice

No part of this Instructions for Use or program may be reproduced, stored in a retrieval system, or transmitted, in any form or by any means, electronic, mechanical, photocopying, recording, or otherwise, without the prior written consent of Auditdata A/S.

Copyright © 2024, Auditdata A/S

Written in Denmark by Auditdata A/S, Denmark.

All information, illustrations, and specifications in this manual are based on the latest product information available at the time of publication.

Auditdata A/S reserves the right to make changes at any time without notice.

Trade name/Product name

PFU+

Primus HIT Pro

Primus Pro

Primus Ice

2000-1 Fitting Unit

Auditdata

1 Introduction	5
2 Abbreviations and Terms	5
3 Symbols Used	7
4 Compliance with Standards	8
5 Intended Use/Indications for Use	10
6 Safety Instructions	11
6.1 Applied parts	11
6.2 Fitting Unit	11
6.3 Fitting and HIT Units	12
6.4 HIT Unit	14
6.5 Contraindications	14
7 Precautions	15
7.1 Principles of Operation	15
7.2 Measurement Accuracy	15
7.3 EMC (Electromagnetic Compatibility) Precautions	16
8 Installation and Set-Up	17
8.1 Hardware Setup	17
8.2 Software Installation	26
8.3 Installing Your License	27
8.4 Test Definitions Set-Up	28
8.5 Configuring Types of Visits	30
8.6 Activating Workflow Support	31
8.7 Activating Transducers	34
8.8 Connecting Transducers to a Sound Booth	34
8.9 Calibration of Free-Field Loudspeakers - Sound Field Calibration	35
8.10 Addition of External Sound Files for Speech Audiometry and Speech Mapping	37
8.11 Calibrating Speech CD Material	39

8.12 Selecting Client and Entering Client Data	40
8.13 Obtaining Hearing Threshold Levels	40
8.14 Shutdown Procedure	44
9 Maintenance	44
9.1 Annual Calibration of Headset and Transducers	44
9.2 Adjustment of Common Headsets and Microphones	44
9.3 Regular System Checks	45
9.4 Inspection	45
9.5 Cleaning	45
9.6 Switching to a new transducer	46
10 Troubleshooting Guide	47
11 Hotline and Technical Support	49
Appendix A	A-1
A.1 Declarations of Conformity	A-1
A.2 Manufacturer	A-6
A.3 Labelling	A-7
Appendix B	B-1
B.1 Technical Specification	B-1
B.2 Technical Data	B-8
B.3 EMC Conformance Requirements	B-11
B.4 Pin Assignments Table	B-14
Appendix C	C-1
C.1 Minimum Requirements (for Software Installation)	C-1

1 Introduction

This document aims to provide instructions on setting up Fitting and HIT Units as well as installing and configuring the Primus software. It also includes essential information on safety measures, maintenance, and calibration.

The Fitting Unit is a general term combining PFU, PFU+, Primus Pro, Primus Ice, and 2000-1 FU hardware units. Please refer to the **Abbreviations and Terms** section for definitions of these units.

Up to version 4.2, the software was released under the name of Primus. The release following Primus 4.2 acquires the name Measure and the version number 6.0.

Depending on your purchased licenses, some of the modules described in this document might not be available in your version of software. Please contact your distributor to get more information on the licenses.

This document is not intended to be a complete reference. For detailed information, please refer to the Help file after installing the software.

2 Abbreviations and Terms

Term	Definition
PFU	PFU stands for Primus Fitting Unit. This includes PFU, PFU+, and Primus Pro hardware units. These units are used to perform pure tone and speech measurements as well as REM and SM measurements.
Fitting Unit	Fitting Unit is the collective name for all fitting unit devices.
Primus Ice	Primus Ice is the name for Primus Audiometer Unit. This unit is used to perform pure tone and speech measurements only.
HIT	HIT stands for Hearing Instrument Test chamber.
AUD	Audiometry.
REM	Real Ear Measurements.
SM	Speech Mapping.
HTL	Hearing Threshold Level. Establishes the minimum level at which the client can detect the presence of a pure tone signal 50% of the time it is presented.

Model name	Product	Additional information
2000 Primus Fitting Unit Pro	Primus Pro	PFU (Primus Fitting Unit) is the collective name for these devices: Primus Pro, Primus Ice and Primus PFU+.
2000 Primus Audiometer Unit Ice	Primus Ice	
PRIMUS FITTING UNIT+ (PFU+)	Primus PFU+	
2000 Primus HIT Pro (2005-1 HIT Unit)	Primus HIT Pro	
2000-1 FU	2000-1 Fitting Unit	<p>2000-1 FU stands for Type 2000-1 Fitting Unit. This Unit is in functionality very similar to the PFU and is also used to perform pure tone and speech measurements as well as REM and SM measurements.</p> <p>In Measure software, the device is displayed as 2000-1 Fitting Unit (Measure Aud).</p>

3 Symbols Used

The following symbols are used in this document and/or on labelling on the device.

Labels on Fitting Unit and HIT Unit



Manufacturing date



Manufacturer's name and address



Disposal instructions



Serial Number



Reference Number



This device is a medical device

Labels only on Fitting Unit



Type B applied parts.
Patient applied parts that are not conductive and can be immediately released from the patient.



Class II equipment



Follow operating instructions



Operating instructions



General warnings



CE - notified body

Labels only on HIT Unit



Caution, please read the Instructions for Use and the User Manual



CE

4 Compliance with Standards

Classification according Annex VIII of EU Medical Device Regulation MDR (EU) 2017/745:

Device	Class	Rule	CE	GMDN	Basic UDI-DI
Primus Fitting Unit (all variants)	Ila	10	CE 0123	45241	05711781DHF2000ZC
Primus Audiometry Unit (Ice)	Ila	10	CE 0123	37503	05711781DHF2000ZC
Primus HIT Pro	I	13	CE	41217	05711781DHF2000ZC
2000-1 FU (2000-1 Fitting Unit)	Ila	10	CE 0123	45241	05711781DHF2000ZC

Note: Medical device classification may vary across different markets depending on local legislation.

All Auditdata devices covered in this manual, including the listed accessories and respective applied parts, comply with the Council Directive RoHS-II/2011/65/EU.

The Fitting System complies with the following standards:

Safety:

- IEC 60601-1:2005+A1:2012 CSV, class 2, type B
- IEC 61010-1:2010 for HIT Unit

EMC:

- IEC 60601-1-2:2014+A1:2020 CSV

Audiometry:

- Tone: IEC 60645-1:2017 / ANSI S3.6:2018 Type 1
- Speech: IEC 60645-1:2017 / ANSI S3.6:2018 Type A or A-E

Real Ear Measurement:

- IEC 61669:2015 and part of ANSI S3.46:2013

Hearing Instrument Testing:

- IEC 60118-7:2005
- IEC 60118-15:2012
- ANSI S3.22:2009

Medical electrical equipment

- EN 60601-1-6:2010+A1:2013+A2:2020

Medical device software

- IEC 62304:2006+A1:2015

Medical devices

- IEC 62366-1:2015
- EN ISO 14971:2019
- EN ISO 13485:2016

5 Intended Use/Indications for Use

The Fitting Unit is intended for use by professionals such as an audiologist, hearing healthcare specialist, or trained clinicians. The devices must only be used for their intended purpose as stated in this document below.

Audiometric testing should take place in a sound treated quiet environment and care should be taken to ensure optimal test conditions and safety of the client during testing.

2000-1 Fitting Unit , PFU and Primus Ice

- The Fitting Unit is intended for performing hearing tests.
- The Fitting Unit with stated accessories is indicated for non-continuous, noninvasive air and optionally bone conduction and speech audiometric testing in quiet office and sound treated environments.
- The Fitting Unit is indicated for use with both paediatric and adult age groups.
- The Fitting Unit is not indicated as a sole means of diagnostics.

2000-1 Fitting Unit and PFU Only

- The Fitting Unit is indicated for non-continuous real-ear measurements at the ear drum by means of noninvasive external ear canal insertion of a probe tube in quiet office environments.
- Finally, the Fitting Unit can be used to present hearing instrument related sound examples through headsets or loudspeakers.

2005-1 HIT Unit

- The Hearing Instrument Test Unit is intended for use by professionals such as an audiologist, hearing healthcare specialist, or trained technician.
- The Hearing Instrument Test Unit is intended to apply sound to the hearing aid in a closed test box and obtain the acoustical output of the hearing aid in a coupler cavity equipped with a microphone.
- The Hearing Instrument Test Unit is intended to be used together with the Software to provide objective indication of the characteristics of a Hearing Aid. Visualization of the obtained coupler microphone signal is only available in the Software application.
- The Hearing Instrument Test Unit is indicated for technical quality inspection or fitting of hearing instruments with no clients involved.

6 Safety Instructions

 PLEASE READ THE SAFETY INFORMATION COMPLETELY BEFORE USING THE FITTING SYSTEM!

6.1 Applied parts

- The headsets / patient switch are only to be used with uninjured skin of the test person. The time of usage is short duration and less than 24 hours.
- Parts that come into contact with the client (that is, transducers, the handheld push-button, and the probe microphone set) should be disinfected before use.

6.2 Fitting Unit

- Parts such as foam tips on insert earphones or probe tubes for real-ear measurement are not intended for reuse. Dispose of such items in a hygienic manner after each client session.
- Do not use talk forward microphone in areas where there is risk of acoustical feedback.
- The headphones supplied must not be used with any other branded equipment. Headphones from other branded equipment must not be used with the system.
- Connect only such headphones and other external devices that are approved for connection to the System.
- Probe tube measurements must be performed by trained professionals only.
- Avoid exposing the client or other persons to unnecessarily high sound pressures, as these may be damaging to hearing.
- Before applying the headphones or insert phone, inspect the patient's ear drum, ear canal, pinna and surrounding areas for lesions or other types of infection. Do not use the headphones or insert phones if any contraindications exist.
- Remove any barriers before placing the headphones or insert phones on the patient, such as jewellery or the patient's hair during the test.
- During real-ear measurements, carefully position the probe tube so as not to contact the ear drum.
- Accessory equipment connected to the analog and digital interfaces must be in compliance with the respective nationally harmonized IEC standards (IEC 60950 for data processing equipment, IEC 60065 for video equipment, IEC 61010-1 for laboratory equipment and IEC 60601-1 3rd for medical equipment). Furthermore all configurations shall comply with MEDICAL ELECTRICAL SYSTEM in IEC 60601-1 3rd.
- Everybody who connects additional equipment to the signal inputs/outputs configures a MEDICAL ELECTRICAL SYSTEM, and is therefore responsible that the system complies with the requirements of the standard IEC 60601-1 3rd. If in doubt, consult the technical service department or your local representative.
- To comply with MEDICAL ELECTRICAL SYSTEM in IEC 60601-1 3rd the Audiometer, equipment parts and ACCESSORY, except for specified Type B applied parts, must be located outside PATIENT ENVIRONMENT, i.e. not closer than approx. 1.5 meters/5 ft.

- The use of accessory equipment not complying with the equivalent safety requirements of this equipment may lead to a reduced level of safety of the resulting system.
Consideration relating to the choice shall include:
 - Use of the accessory in the PATIENT VICINITY.
 - Evidence that the safety certification of the ACCESSORY has been performed.
 - In accordance to the appropriate IEC 60601-1 3rd.

6.3 Fitting and HIT Units

6.3.1 Maintenance and Cleaning

- Do not modify the equipment without authorization of the manufacturer.
- Maintain a high level of hygiene and clean reusable devices which come into contact with clients between each use. See the cleaning instructions below.
- For cleaning use only a soft dry cloth dampened very sparingly with a low level disinfectant solution such as isopropyl alcohol to wipe the device. Do not allow excess solution to enter the device as this may damage internal components.
- Do not use acetone or paraffin/kerosene-based solutions, or any other harsh solvent to clean the device or its accessories. Use of such substances may be harmful to the equipment and may result in faulty operation.
- The headphones, probe microphone set, cables, connectors and other electrical accessories are not waterproof. See the [Cleaning instructions](#) for safe handling.

6.3.2 Usage

- The system with attached accessories is to be operated by qualified personnel only.
- The device is intended only as an adjunct in client assessment. It must be used in conjunction with assessment of clinical indicators and symptoms.
- The main power supply should be easily accessible for plugging/unplugging.
-  If the PC complies with IEC 60950 or with IEC 60601-1 3rd, use the USB cord to connect to the system. Do not touch the USB connector from the PC and the patient at the same time, when a IEC 60950 approved PC is used.
- The device should be directly connected to the PC and not to a USB hub.
- Do not use defective equipment. If you suspect a malfunction, contact a service representative authorized by manufacturer for inspection of the equipment.
- On a regular basis, that is, at least once a week, perform a visual inspection of the Fitting and HIT Units and their accessories for visible damages. Do not use damaged headphones or accessories with the device. During use, evaluate the test results and perform a system inspection if the results appear unreliable.
- When using the device with insert phones or probe-tube set, note that the used foam ear tips or probe tube should be disposed in a manner consistent with normal infection control procedures.

- In the event of irreparable damage to the device, dispose of it through an approved hazardous materials disposal facility in accordance with the RoHS (Restriction of the Use of Certain Hazardous Substances) and WEEE (Waste Electrical and Electronic Equipment) regulations, or return it to manufacturer.
- Do not connect non-medical equipment unless it forms part of the medical system. There is a danger that the leakage currents may exceed their valid limits and consequently be a hazard to the client and the examiner.
- The devices should be contained in an environment according to the operational specifications, so that the temperature and humidity does not rise above dangerous measures. Refer to [B.1 Technical Specification](#) for allowed temperature, humidity, and air pressure.
- Do not expose the device to moisture. Extreme moisture can cause the device to fail or perform inaccurately.
- The devices must only be used for their intended purpose.
- All tests must be conducted in a sound treated or sound proof room with low ambient noise.
- Excessive movements should be avoided during the test, as it may interfere with the measurement and can result in wrong measurement results.
- The headset and transducers delivered with the Fitting System and reference and coupler microphones delivered with the HIT Unit are NOT intended for calibration by users. Contact your local distributor for your annual service and calibration.
- Do not pull the headphone cable. To disconnect the headphones or other accessories from the device, pull the plug.
- The examiner should take care never to touch non-medical parts of the system and the client at the same time.
- **EXPLOSION HAZARD:** Do not use the device in the presence of flammable substances.
- **ELECTRIC SHOCK HAZARD:** Do not attempt to disassemble the device. The device contains no user-serviceable items inside.
- Carefully route all the cables to reduce the possibility of entanglement or strangulation.
- Fasten the Fitting Unit on a wall, under a table or place it on a stable surface. If considered more practical, the Fitting System can also be placed inside the audiometric booth or piggyback to the HIT unit. Place the HIT Unit on a stable surface.
- Do not place the system on or near equipment that generates a strong magnetic or electrical field, as this may cause improper operation and interfere with the intended use of the device.
- If mobile multi-outlet power strips for mains power supply are in use:
 - they must comply with MEDICAL ELECTRICAL SYSTEM in IEC 60601-1 3rd
 - their rated current must not be exceeded
- Cables should be changed by properly qualified personnel only.
- Any external equipment should be connected in such a way that the Fitting Unit with connections still observes the safety requirements in IEC 60601-1 3rd.
- Conductors and wiring between the system components must be protected against mechanical damage.

- If the PC is in use and not compliant with IEC 60950 or IEC 60601-1 3rd, use optical USB connection Type OPTICIS M2-100-03 with power supply type Friwo FW7662M/05, type Friwo FW8002M/05 or optical USB connection Type IF-TOOLS; ISOUSB-BOX-PLUS; Art. No.: 14000.
- Use only with the power supply that is supplied with the system - type Friwo FW7362M/15 or type Friwo FW8030M/15.
- Any serious incident that has occurred in relation to the device should be reported to the manufacturer and the competent authority of the Member State in which the user and/or patient is established.

6.4 HIT Unit

- The Hearing Instrument Test Unit is a laboratory equipment and must not come into contact with the patient. The hearing instrument used in the HIT Unit must NOT be connected to HIT Unit and the patient at the same time.

6.5 Contraindications

- Patients unable to cooperate because of young age or other conditions cannot undergo pure tone or speech audiometry. They may need to have the auditory system tested by other methods.
- The patient shall be asked about any exposure to loud noise during the previous 24 hours, as this can cause a temporary hearing loss. If the answer is yes then it may be necessary to re-test the subject at a time when they have had no recent exposure to noise.
- Audiometry shall be preceded by otoscopic examination. Occluding wax may be removed prior to audiometry but if wax is removed the procedure shall only be undertaken by someone who is qualified and competent to do so.

7 Precautions

7.1 Principles of Operation

7.1.1 Audiometry

- Presentation of pure tone sine wave and speech stimuli for threshold determination and supra-threshold testing within the range of 125 Hz to 16 kHz and varying intensity levels to assess client hearing levels.

7.1.2 Real Ear Measurement

- Please also note the REM standard IEC 61669 mentioned in [Chapter 4](#). Besides technical specifications, terms and definitions, it contains additional helpful recommendations regarding the test set up, such as location of subject and tester, or location of field reference and measurement point.

Presentation of pure tone sine wave or complex stimuli within the range of 125 Hz to 16 kHz for measurement at the ear drum by means of a flexible probe tube inserted into the ear canal. The measurement may take place with or without a hearing instrument inserted.

7.1.3 Hearing Instrument Test System

- Presentation of pure tone sine wave or complex stimuli through a loudspeaker or teleloop system within the range of 125 Hz to 16 kHz. Measurement and quality inspection of hearing instruments in a dedicated hearing instrument test chamber.

7.2 Measurement Accuracy

If the accuracy of the device measurements does not seem reasonable, check the device for proper functionality. The measurement and signal presentation data, including stability, exactness and tolerances appear from the section [Technical Specification](#).

Inaccurate measurements may be caused by factors such as:

- Excessive ambient noise in the test environment
- Excessive movements by client or operator
- Occlusion of the outer ear by hair or jewellery, or occlusion of the ear canal by objects or cerumen
- Incorrect placement of headphones, probe microphone set or free-field loudspeakers

- Incorrect headphones, loudspeakers or probe microphone set, or components such as cables, ear cushions, etc.
- Malfunction of the headphones or the device

 **WARNING!** Use of the device in any way other than as described in this document may result in inaccurate results or injury.

7.3 EMC (Electromagnetic Compatibility) Precautions

The system is suitable for use in all establishments other than domestic, but it can be used in domestic establishments and those directly connected to the public low-voltage power supply network that supplies buildings used for domestic purposes, if the following warning is taken in account:

 **WARNING!** This system is intended for use in professional healthcare environment only and might interfere or be disturbed by nearby equipment, therefore, it may be necessary to take mitigation measures, such as reorienting, relocating or shielding the location.

Install and operate the System according to the EMC information, warnings and recommendations to prevent adverse events to the patient and operator due to electromagnetic disturbances for the expected service life time.

 **WARNING!** Failure to comply with the precautions listed in this section may cause presenting of unwanted hearable noise or a wrong output on patients headset and therefore the possibility of wrong client response.

 **WARNING!** Do not place the system on or near equipment that generates a strong magnetic or electrical field, as this may cause improper operation and interfere with the intended use of the device.

RECOMMENDATION: To reduce the frequency of electrical shocks through ESD, the floors should be wood, concrete or ceramic tile. If floors are covered with synthetic material, the relative humidity should be at least 30%.

RECOMMENDATION: The quality of the mains power should be that of a typical commercial or hospital environment.

 **WARNING!** Use of this equipment adjacent to or stacked with other equipment should be avoided because it could result in improper operation. If such use is necessary, this equipment and the other equipment should be observed to verify that they are operating normally.

 **WARNING!** Use of accessories, transducers and cables other than those specified or provided by the manufacturer of this equipment could result in increased electromagnetic emissions or decreased electromagnetic immunity of this equipment and result in improper operation.

 **WARNING!**: Portable RF communications equipment (including peripherals such as antenna cables and external antennas) should be used no closer than 30 cm (12 inches) to any part of the System including cables specified by the manufacturer. Otherwise, degradation of the performance of this equipment could result.

For more information on the conformance of the system with the EMC standard EN 60601-1-2, refer to [Appendix B](#).

8 Installation and Set-Up

This installation procedure assumes that you will make a full installation. Skip irrelevant parts, if you are not going to install all the modules.

Be sure to observe the safety requirements stated in this document, both during installation and whilst using the Fitting system's instrumentation and transducers. Do not connect external devices unless they are suitable for connection to the Fitting System.

8.1 Hardware Setup

Note: No user-serviceable parts are found inside the Fitting Unit. Do not disassemble or modify the unit!

8.1.1 Package and unpacking

External Inspection

Although your audiometer system parts were carefully tested, inspected and packed for shipping, immediately examine the outside of the container after receiving the instrument for any signs of damage. Notify your carrier if you observe any damage.

Unpacking

Carefully remove your audiometer system parts from its shipping container. If you observe any mechanical damage, notify the carrier immediately so that a proper claim can be made. Be certain to save all packing material so that the claim adjuster can inspect it as well. As soon as the carrier has completed the inspection, notify your Auditdata representative.

If the instrument must be returned to the supplier, repack it carefully (in the original container, if possible) and return it prepaid to the supplier for the necessary adjustment.

Package contents

Check carefully that you have got all system parts according to the delivery note.

If any system part is missing or the delivery is not according to your order, notify your Auditdata representative immediately.

8.1.2 Fitting Unit setup procedure

1. Unpack the Fitting System and cross-check that all ordered parts (as indicated on the delivery note) are included. If any parts are missing, please contact your manufacturer for support immediately.
2. Slot the appropriate connector to your power supply.

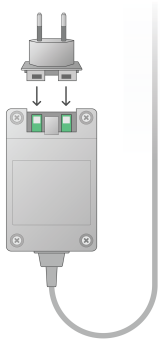

3. Fasten the Fitting Unit on a wall, under a table or place it on a stable surface. (If considered more practical, the Fitting System can also be placed inside the audiometric booth) or piggyback to the HIT unit.
 4. Connect the USB cable to the inlet marked USB on the Fitting Unit.
 5. Connect the other end of the USB plug into an empty slot on the operator PC.
 6. Connect the power adapter to the DC inlet.
 7. At the other end, connect the power plug to a power socket.
-
8. The plugs on the individual transducers come in specific colours, and should be plugged into the connector marked with the same colour on the Fitting Unit. The name of the connector is indicated next to the colour-marking on the Fitting Unit (see the table under the picture).

2000 Primus Fitting Unit Pro, Primus PFU+

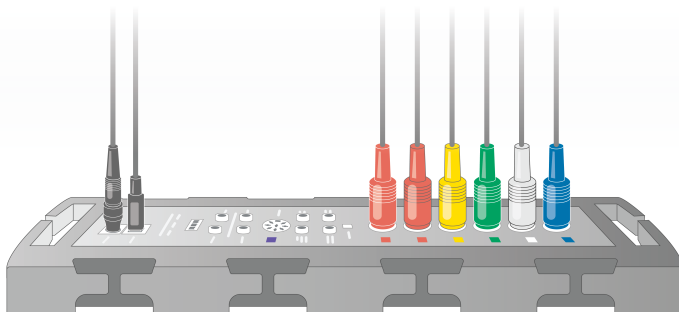

No	Table: Connectors for use in the Fitting Unit (plug/type in parenthesis)	Name on the Fitting Unit (and colour of transducer connectors if highlighted)
1	DC power adapter (pin/hole)	DC power
2	USB cable (USB type B, 2.0)	USB
21	Sony/Philips Digital Interconnect Format	S/PDIF*3
3	Free Field Speaker, left (passive type) (Anitek, H5-02-1-0-5-0)	Left
4	Free Field Speaker, middle (passive type) (Anitek, H5-02-1-0-5-0)	Mid
5	Free Field Speaker, right (passive type) (Anitek, H5-02-1-0-5-0)	Right
6-8	Free Field Line Out (3.5 mm Stereo Mini Jack for connecting active speakers or amplifiers)	Left/Right - Rear - Sub/Mid*1*2 Line Out 1 - Line Out 2 - Line Out 3*3
9	Client/Demo Headset (3.5 mm Stereo Mini Jack)	Client Headset*1*2 Demo Headset*3
10	Option (DIN 8 pin)	Option*2*3
11	Operator microphone, left (3.5 mm Stereo Mini Jack)	Left Operator Microphone
12	Operator microphone, right (3.5 mm Stereo Mini Jack)	Connector not used
13	Talk-back microphone(3.5 mm Stereo Mini Jack)	Talk Back Microphone
14	Operator headset for monitoring (3.5 mm Stereo Mini Jack)	Monitor Headset
15	Air conductor (DIN 8 pin)	Air Conductor 1*4 Air Conductor 2*4 Air Conductor 3*4
16	Alternative air conductor (DIN 8 pin)	Air Conductor 1*4 Air Conductor 2*4

No	Table: Connectors for use in the Fitting Unit (plug/type in parenthesis)	Name on the Fitting Unit (and colour of transducer connectors if highlighted)
		Air Conductor 3 ^{*4}
17	High-frequency air conductor (DIN 8 pin)	Air Conductor 1 ^{*4} Air Conductor 2 ^{*4} Air Conductor 3
18	Bone conductor (DIN 8 pin)	Bone Conductor
19	Client Response push button (DIN 8 pin)/Free field calibration tool (DIN 8pin)	Client Response
20	Probe microphone set (DIN 8 pin)	Primus Probe ^{*2} Real Ear Probe ^{*3*4}

*1 This plug is only available in the PFU.

*2 This plug is only available in the PFU+.

*3 This plug is only available in the Primus Pro.

*4 Frequency above 8 kHz will be unavailable.

2000-1 Fitting Unit

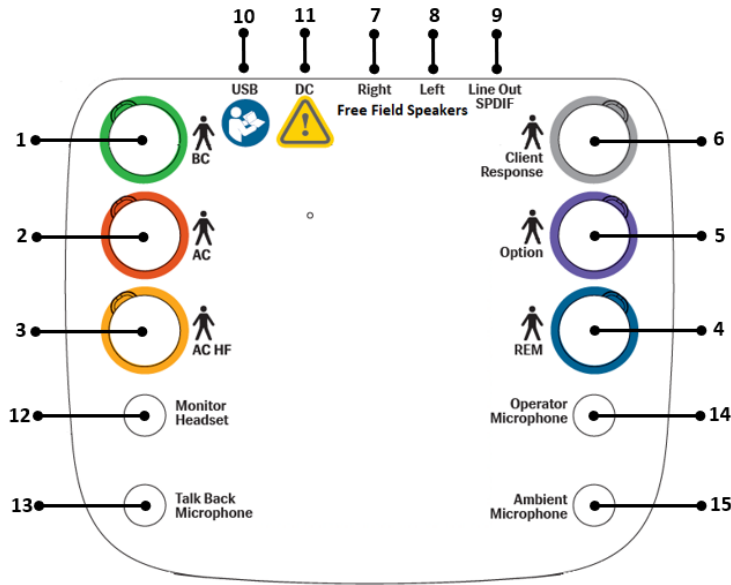

No	Table: Connectors for use in the Fitting Unit (plug/type in parenthesis)	Name on the Fitting Unit (and colour of transducer connectors if highlighted)
1	Bone conductor (Mini DIN 8 pin)	BC (Green)
2	Air conductor (Mini DIN 8 pin)	AC
3	High-frequency air conductor (Mini DIN 8 pin)	AC HF (Yellow)
4	REM probe microphone set (Mini DIN 8 pin)	REM (Blue)
5	Option (DIN 8 pin)	Option (Purple)
6	Client Response Push Button (Mini DIN 8 pin) OR Free field calibration tool (Mini DIN 8 pin)	Client Response (Grey)
7	Free Field Speaker, right (passive type) (Anitek, H5-02-1-0-5-0)	Free Field Speakers, Right
8	Free Field Speaker, left (passive type) (Anitek, H5-02-1-0-5-0)	Free Field Speakers, Left
9	Free Field Line Out (3.5 mm Stereo Mini Jack for connecting active speakers or amplifiers) OR	Line Out / SPDIF

No	Table: Connectors for use in the Fitting Unit (plug/type in parenthesis)	Name on the Fitting Unit (and colour of transducer connectors if highlighted)
	SPDIF: Sony/Philips Digital Interconnect Format (toslink)	
10	USB cable (USB type C)	USB
11	DC power adapter (pin/hole)	DC
12	Operator headset for monitoring (3.5 mm Stereo Mini Jack)	Monitor Headset
13	Talk-back microphone (3.5 mm Stereo Mini Jack)	Talk Back Microphone
14	Operator microphone, left (3.5 mm Stereo Mini Jack)	Operator Microphone
15	Connector not used	Ambient Microphone

Primus Ice

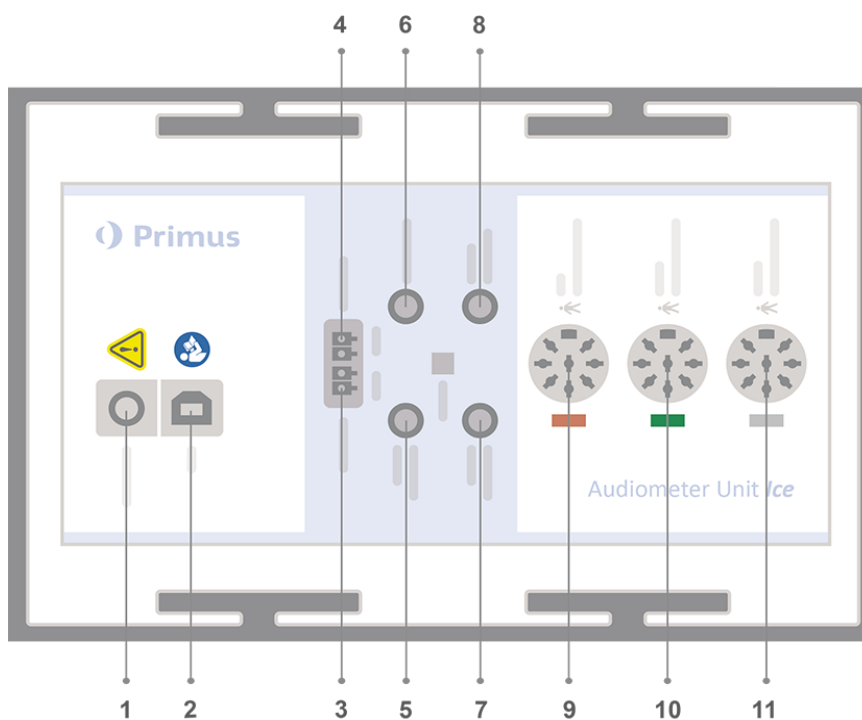

No	Table: Connectors for use in the Fitting Unit (plug/type in parenthesis)	Name on the Fitting Unit (and colour of transducer connectors if highlighted)
1	DC power adapter (pin/hole)	DC power
2	USB cable (USB type B, 2.0)	USB
3	Free Field Speaker, left (passive type) (Anitek, H5-02-1-0-5-0)	Left
4	Free Field Speaker, right (passive type) (Anitek, H5-02-1-0-5-0)	Right
5	Operator microphone (3.5 mm Stereo Mini Jack)	Operator Microphone
6	Free Field Line Out (3.5 mm Stereo Mini Jack for connecting active speakers or amplifiers)	Line Out/Demo
7	Talk-back microphone (3.5 mm Stereo Mini Jack)	Talk Back Microphone
8	Operator headset for monitoring (3.5 mm Stereo Mini Jack)	Monitor Headset
9	Air conductor (DIN 8 pin)	Air Conductor
9	High-frequency air conductor (DIN 8 pin)	Air Conductor*1
10	Bone conductor (DIN 8 pin)	Bone Conductor
11	Client Response push button (DIN 8 pin)/Free field calibration tool (DIN 8pin)	Client Response

*1 Frequency above 8 kHz will be unavailable.

9. Connect the speakers into the speaker inlets.
10. **Optional:** Connect the operator microphones, headset and additional freefield speakers to the appropriate sockets (see the above lists).
11. Make sure that all cables are routed and fastened to prevent a hazard (such as entanglement) to personnel or clients.
12. Close the Fitting Unit using the lid.

Note: The unit has no physical user interface (apart from the on/off lamp, which is visible through the lid itself). Hereby, in order to protect it from dust and unintended disassembly, it is recommended to keep the lid on during use.

8.1.3 HIT Unit setup procedure

1. Place the HIT Unit on a stable surface.
2. Connect the USB cable to the inlet marked USB on the HIT Unit. Connect the other end of the USB plug into an empty slot on the operator PC. Connect the power adapter to the DC inlet, if performing tests are up to 16kHz.
3. To adjust hearing aid settings with HI-PRO or NOAHlink™, connect the HI-PRO box or NOAHlink™ to the appropriate INTERNAL HI CONNECTOR outlet using the extension cables provided (as shown in the picture below).

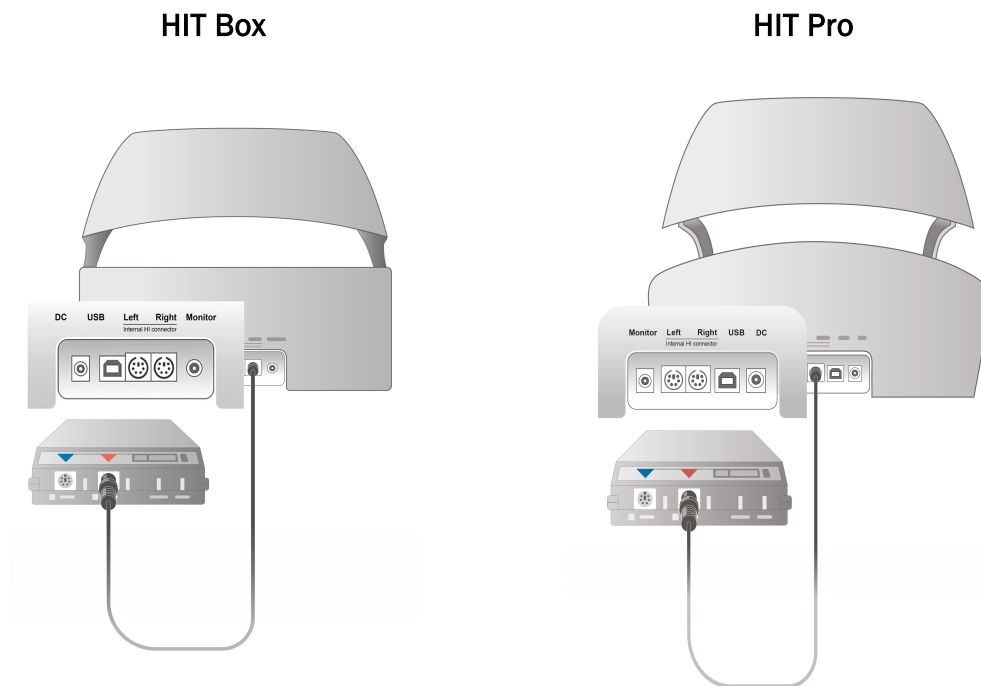

4. Plug in the hearing aid programming lead to start programming with a HI-PRO or NOAHlink™.

Note: You can also connect the HI-PRO box or NOAHlink™ directly to the operator PC. The plug in the hearing aid programming leads directly to the HI-PRO box.

HIT Box

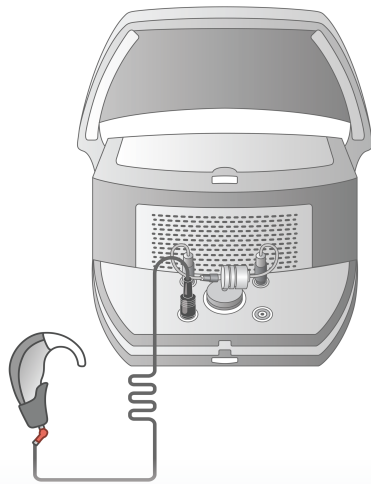

HIT Pro

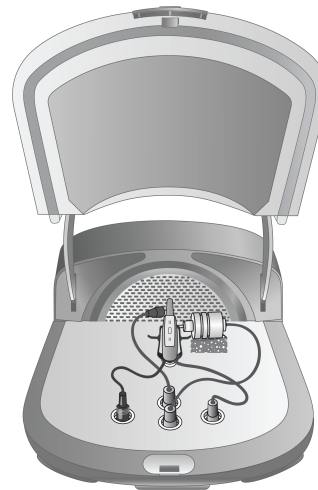

5. **Optional:** Connect a monitor headset to the MONITOR socket.

HIT Box

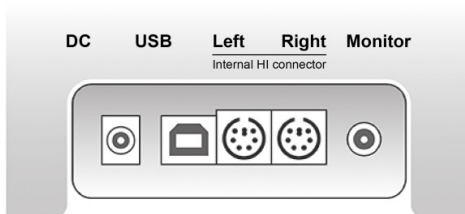

HIT Pro

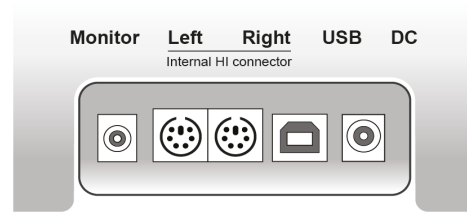

6. Plug the reference microphone, coupler and battery pill in the inlets as shown below. You can also place the necessary sponge provided to support the hearing aid. Please refer to Section 9.2, **Set up and editing for hearing instruments** in the User Manual for more information.

HIT Box

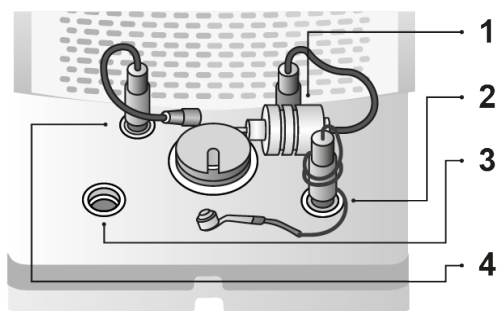

HIT Pro

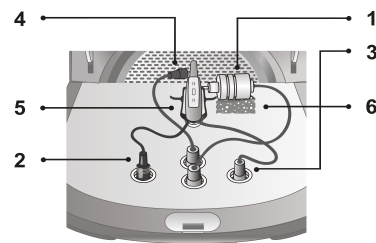

No	Name
1	Coupler microphone
2	Battery pill
3	Hearing aid programming lead (HI-Pro cable)
4	Reference microphone
5	Hearing aid holder
6	Coupler microphone holder

8.2 Software Installation

8.2.1 Prerequisites

At least version 4.7 (or higher) should be installed if you are using NOAH.

8.2.2 Installation Procedure

You will receive the software installation file on a USB memory stick. Insert the USB stick into a USB slot.



The installation should now start automatically. Follow the instructions on the screen.

If the installation does not start automatically, do as follows:

1. Open Windows Explorer and locate the USB stick.
2. Locate the **setup_x.x.x.x.exe** file and double-click it.
3. The installation program will now guide you through the installation procedure.
4. Follow the instructions on the screen.

Note: Starting from version 2.1.0.0, you will need to install an additional driver for the Video Otoscopy module. During the installation of the software, you will be asked to allow the installation of these drivers. You must click **Install** or the installation will be cancelled.

8.2.3 Updates

When a new software version is available, you can download it from the Internet. Open Auditdata A/S' homepage, www.auditdata.com from the Support section.

8.3 Installing Your License

8.3.1 Cloud-based License Activation

For Auditdata Cloud solution users, the system will automatically download and install licenses. Ensure the hardware is connected to the computer and there is an internet connection. You will see a notification once the license has been successfully added. To complete the installation, restart the application.

8.3.2 Manual license activation

If the application cannot download the license from the cloud, you can manually enter the license code:

1. In the **License Notification** dialog box, click **Show License Info**.
2. In the **License Information** dialog box, go to the **Licenses** tab.
3. You have two options: **Import** and **Enter Code**.

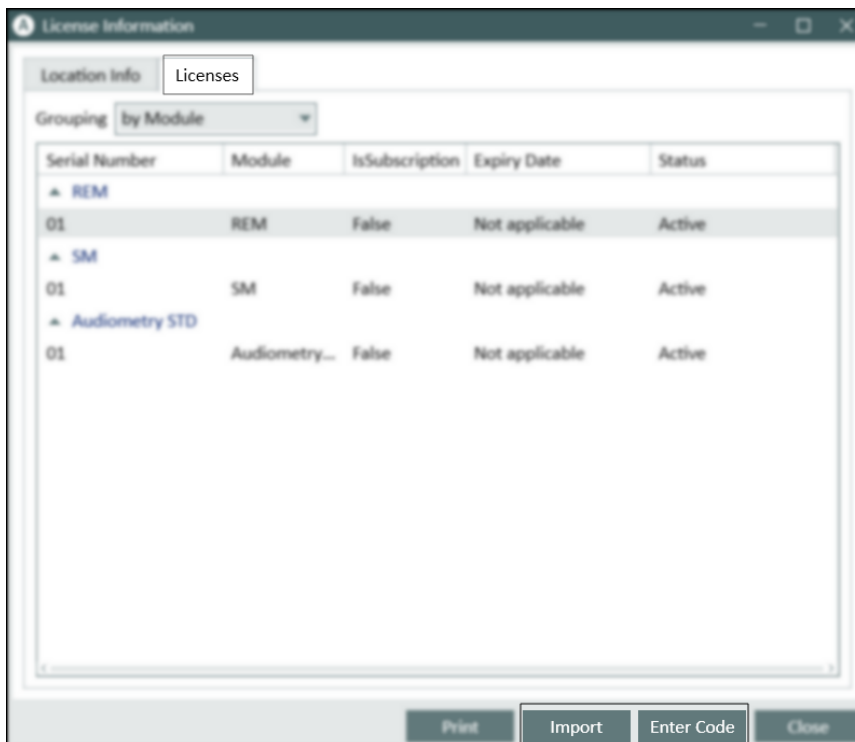

- Click **Import** to navigate to the location of the license file, then click **Open**.
 - If you have the license code, click **Enter Code** and enter your unique key, then click **OK**.
4. Restart the application to complete the installation of the license.

8.3.3 Calibration and Adjustments

After completing the software installation and hardware setup, proceed to calibrate the free field loudspeakers (if any) and make an initial adjustment of the attached microphones and headsets. After calibration and adjustment, the system is ready for use.

To view information on connected devices and calibrations, go to **Tools > Device Management**.

8.4 Test Definitions Set-Up

Test definitions are pre-configured measurements based on the test types available within the system. You can locate them by opening **Tools** and then clicking **Test Definitions**.

Use the **Add**, **Edit** and **Remove** buttons to set up test definitions for the main modules, namely: **Audiometry**, **Real Ear Measurement**, **Speech Mapping** and **HIT**.

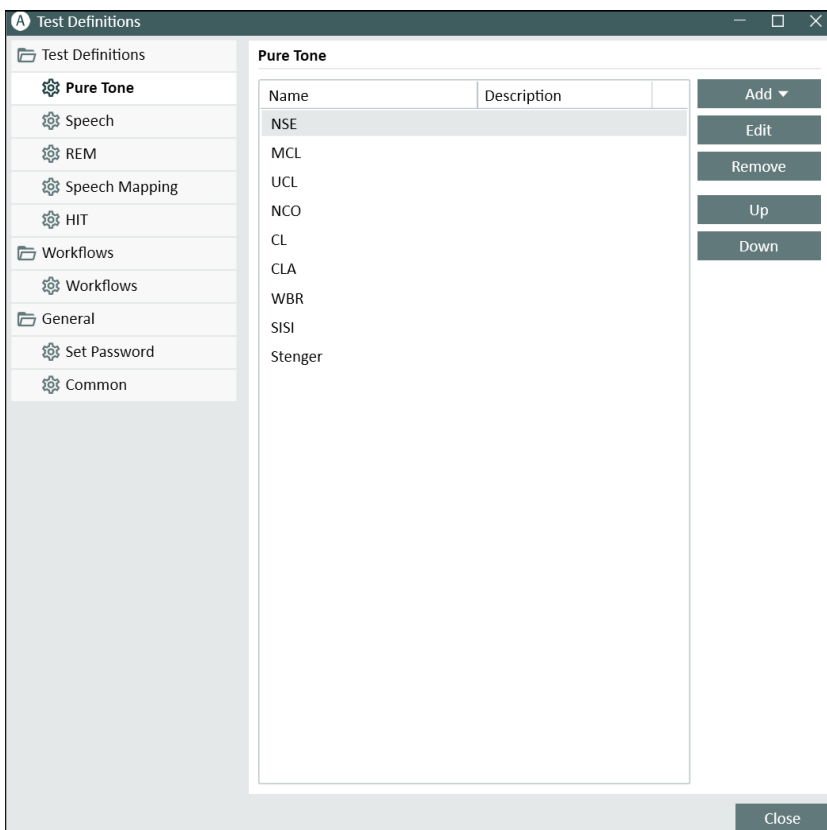

You can create and name new custom test definitions for each measurement by configuring the signal type, level, transducer, masking stimulus for each test.

Editor For Test Definition

General | **Frequencies** | Curve Styles | Rules | Masking assistant

Name: HTL

Description:

Test Type: HTL | Aided Condition: Unaided

Shortcut: H

Stimulus: Signal Type: Pulsed Pure Tone | Transducer: Insert Earphone [NOT CONNI] | Interrupter: Stimuli when pressed | Default Ear Side: Right

Masking: Masking | Signal Type: Narrowband Noise | Transducer: Insert Earphone [NOT CONNI] | Default Level, dB: 50 | Masking Side: Opposite

Level Preselection: Start Level: 50 | Reset Mode: No Level Preselection | Reset Level: []

Other Settings: Step Level: 5 dB | UCL Limiter: None

Minimum point repetitions for threshold

Repetitions needed: 2 | dB Reset: 10

OK | Cancel

It is also possible to specify the completeness criteria by checking that the selected frequencies are measured during the test.

Enable consistency criteria to check whether AC and BC thresholds need to be masked. Also, check that the threshold levels are according to the following rule: $UCL > MCL > HTL \geq BCL$.

Editor For Test Definition

General | Frequencies | Curve Styles | **Rules** | Masking assistant

Enable mandatory frequencies check

Check that the following frequencies are measured:

<input type="checkbox"/> 125	<input checked="" type="checkbox"/> 250	<input checked="" type="checkbox"/> 500	<input type="checkbox"/> 750	<input checked="" type="checkbox"/> 1000	<input type="checkbox"/> 1500	<input checked="" type="checkbox"/> 2000
<input type="checkbox"/> 3000	<input checked="" type="checkbox"/> 4000	<input type="checkbox"/> 6000	<input checked="" type="checkbox"/> 8000	<input type="checkbox"/> 9000	<input type="checkbox"/> 10000	<input type="checkbox"/> 11200
<input type="checkbox"/> 12500	<input type="checkbox"/> 14000	<input type="checkbox"/> 16000				

Consistency check

$UCL > MCL > HTL \geq BCL$

Check that stimulus was played before store

Enable interoctave frequencies check

Check that the following frequencies are measured:

750 | 1500 | 3000 | 6000 | Threshold value: 20 dB HL

Enable ambient noise monitoring warnings

Maximum permitted uncertainty: 2 dB

Stop measurement when ambient noise is high

OK | Cancel

More details about setting up various modules can be found in the System’s Help.

8.5 Configuring Types of Visits

The Types of visits list itself is available right below the Client tab.

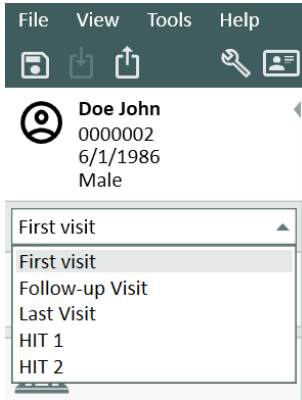

The application is shipped with a set of predefined visits. You can add, delete or edit them. To do this, open the **Tools** menu, click **Settings**, then **Workflow** in the General section, and use **Add/Delete/Edit** buttons as needed.

If you do not wish to use some of the modules, you may disable it by deselecting the check box under the **Enable modules** heading. Those modules will now not be shown in the workflow list on the main screen.

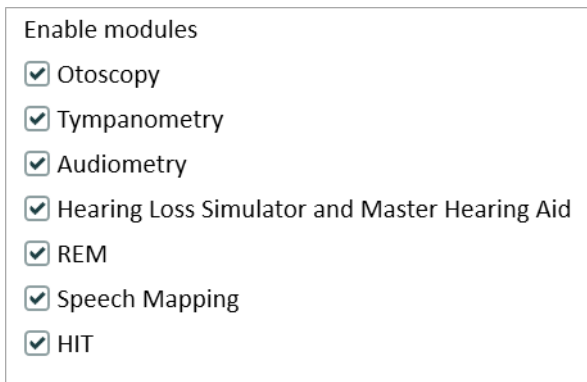

Each task group consists of relevant tasks which you can select using the arrow buttons to move to the selected tasks box to add to your workflow. Once you have selected all your tasks required, use the **Up** and **Down** button to change the order of your selected tasks.

In the main window of the application, the task groups are represented by the tabs located right below the task list.

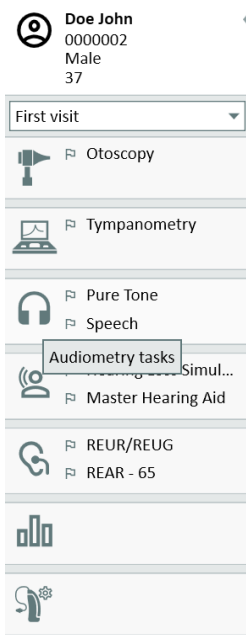

8.6 Activating Workflow Support

The system includes a workflow support utility which guides you through the necessary measurements step by step. The purpose is to provide the ability to follow company defined test protocols and open the particular test steps in their predefined configuration. For each workflow step you can define type of measurement, stimulus, level, frequencies, etc. It is possible to set each workflow step as an optional or mandatory step.

You can define as many workflows as you want depending on your needs. However, only one workflow can be activated at a time.

To enable workflow support, go to **Tools** and select **Settings** where you click the **Workflow** tab. Select the corresponding check box to activate workflow support.

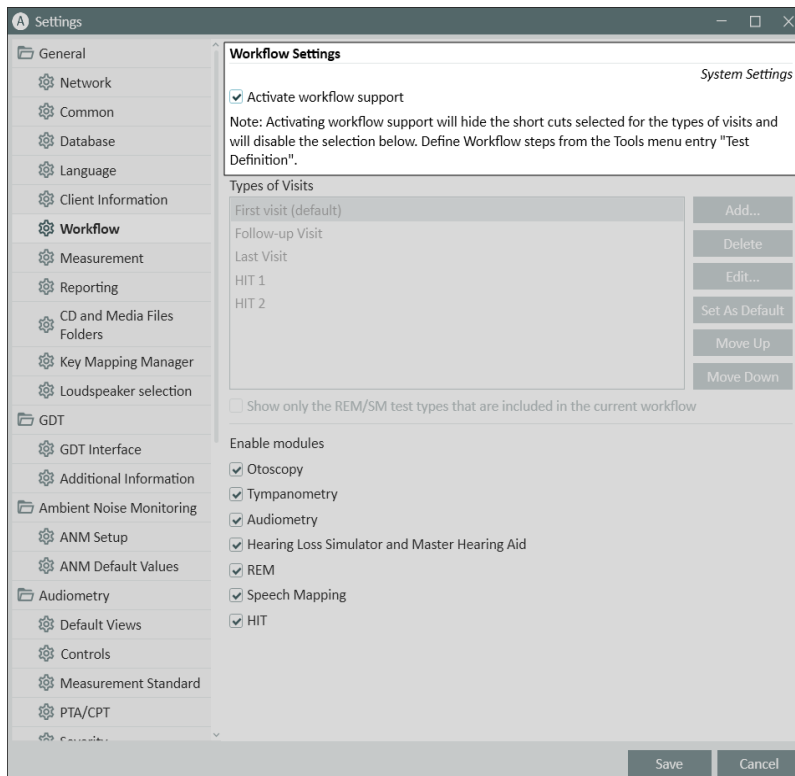

Note: Activating workflow support disables the types of visits functionality in the user interface.

To configure workflows, go to **Tools** -> **Test Definition**. Select a workflow entry from the list and click **Edit** to open it. Use the buttons in the right panel to add new workflows, edit existing ones or delete any workflow from the list.

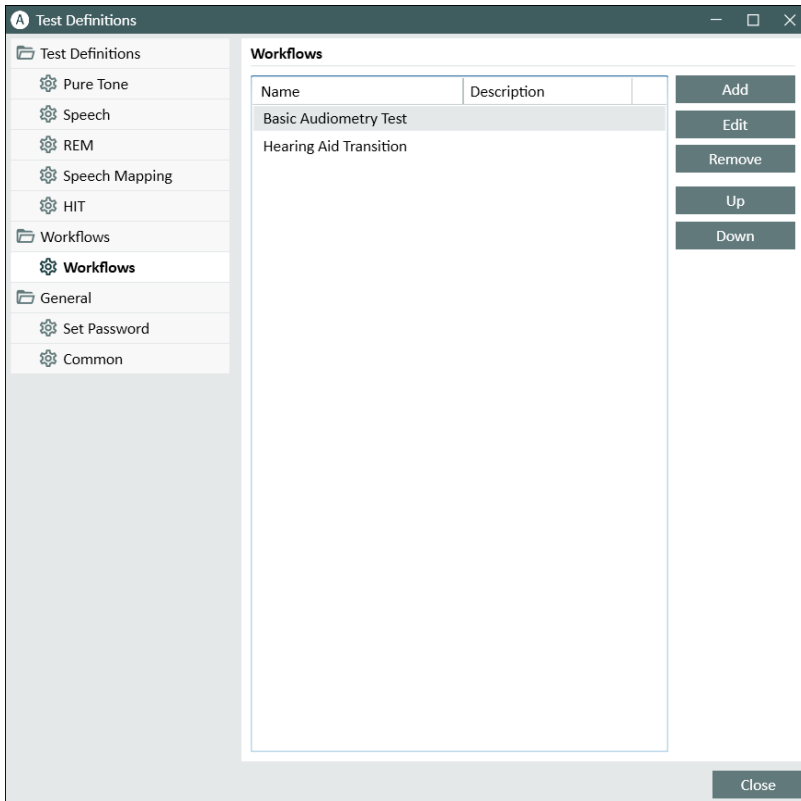

To define the steps within the workflow, click the **Edit** button to open the configuration window.

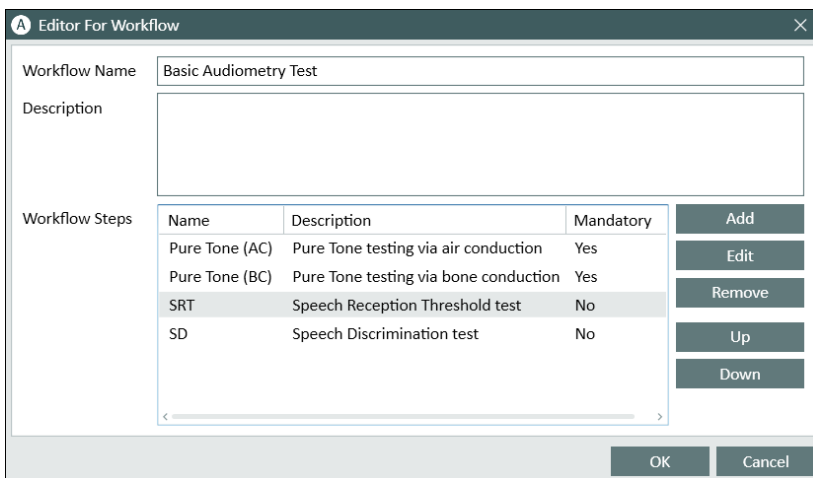

As you add the steps, you need to specify the test type, set its prospected duration and set test step as mandatory or optional.

Note: There are three specific step types that display a message to the audiologist, prompt them to enter a note, open an external file (website or presentation), called **Display a message**, **Prompt a user to add a note**, and **Open External Link** correspondingly.

After restarting the software, you can find the workflow on the top panel of the application.

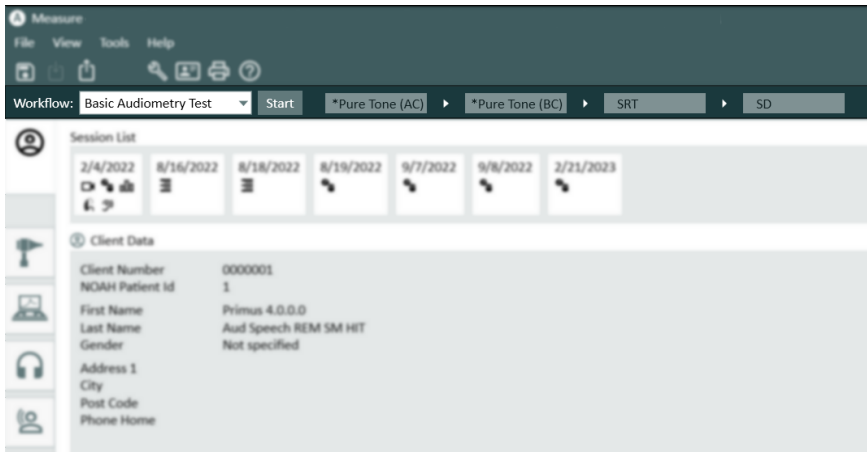

After the workflow support has been activated, click the **Start** button to begin. The first workflow step will be highlighted and after clicking on it you will be directed to the corresponding module and the preconfigured test will open up. Each step is coloured according to its state:

- Yellow - Incomplete
- Green - Done
- Red - Skipped
- Dark Grey - Active Step
- Blue - Not Done

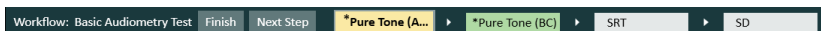

If the criteria for the test type are not fulfilled, the application will notify you when you attempt to move to the next step. You can see what criteria was not met and make required changes to the measurement.

You must enter a reason why the criteria cannot be fulfilled or change the test to meet the criteria requirements.

8.7 Activating Transducers

The transducers used with the Fitting Unit need to be activated before usage. To start the activation:

1. Run the application.
2. Insert the transducer plug into the appropriate socket.
3. In the pop up window click **Activate**.
4. Your transducer is now activated.

8.8 Connecting Transducers to a Sound Booth

To connect a transducer to a sound booth, please do the following:

1. Run the application and plug in the transducer into the Fitting Unit.
2. Disconnect the transducer. Do not restart the software.

3. Plug in a sound booth cable into the same plug that was used for the transducer.
4. The system will show the dialog with data from the last connected transducer.
5. Verify that the right transducer is connected.
6. You can now connect your transducer to a sound booth.

8.9 Calibration of Free-Field Loudspeakers - Sound Field Calibration

Free-field loudspeakers must be calibrated before performing any audiometric testing.

The calibration of the free-field loudspeakers is only valid for the exact distance from the client's ear for which they are calibrated at.

Therefore, free-field loudspeakers should be re-calibrated if they are moved from the exact location at which they were calibrated.

For the following procedure it is assumed that the connected loudspeakers are of a high quality, particularly with respect to linearity and maximum sound pressure.

Procedure

1. Place the free-field loudspeakers at a distance no further than 1 m and angle the speakers, for example at 45° or 0° azimuth from where the client's ear will be during tests. The center of the loudspeaker should be at the same height as the ear canal.

Note: The calibration must be repeated if the client has moved from the original calibration distance.

2. In the case of active loudspeakers, make sure that the volume is set to maximum.

Note: Some active loudspeakers may be too sensitive and will produce distortion noise, when set at maximum volume. In that case, try to reduce the volume (if max. output can be reached) until you find a level where max. output level can still be reached and noise from the loudspeaker system is acceptable.

3. Open the Fitting System program, go to **Tools > Settings > General > Loudspeaker selection** and select the correct speaker for pure tone, speech, REM, and SM according to your setup.

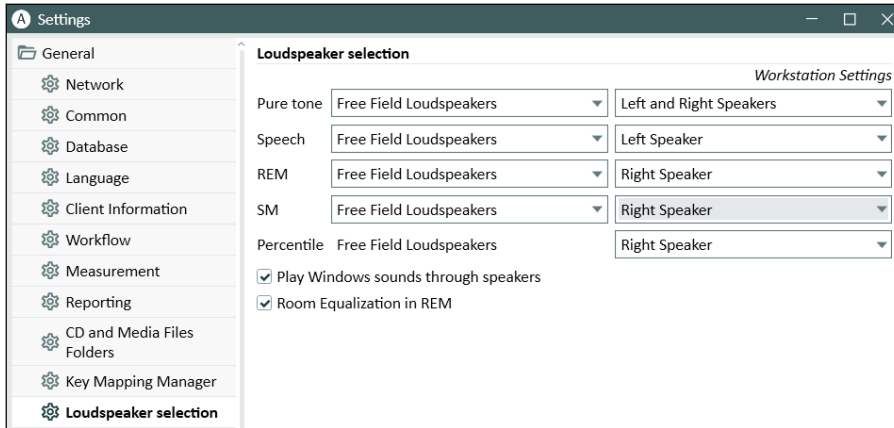

4. Click **Save** to confirm the specified settings.
5. Select **Sound Field Calibration** from the **Tools** menu.
6. The window contains the history of performed calibrations. Click **Do Calibration** to start a new calibration.
Note: A password is required to access this function. Enter the following password - "primusFFcal".
7. In the **Calibration of Free Field Loudspeakers** dialogue box, enter the name of the technician who performs the calibration, select the module you want to calibrate and a calibration method.

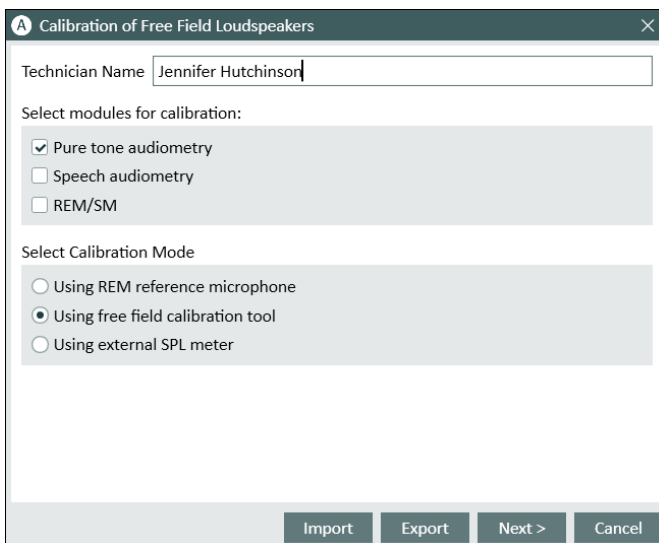

8. If you have selected external SPL meter, in the next Setup window, select the speakers you wish to calibrate.

Also check-mark the box at the bottom if the calibration should include the high-frequency area.

Note: High frequency calibration option is only available when the pure tone audiometry module is selected.

If you are using the built-in microphone, select Left or Right Probe-mic to measure the levels with.

Note: The REM probe microphones must be calibrated before being used to calibrate the loudspeakers.

If you are using the free field calibration tool, levels will be measured with the free field calibration microphone.

Note: When using the Primus Ice, you should calibrate by selecting the external SPL meter or the free field calibration tool.

9. Set the level you wish to calibrate at.
10. Select **Speech Noise- ILTASS** for signal for sound card calibration.
11. Place the SPL meter, free field calibration microphone, or Real Ear Probe at the exact location where the client's ear will be tested.
12. Observe the instructions at the top of the **Setup** window, and click the **Start** button. (You will get a warning, if any selected instruments are not connected and turned on).

If you use the SPL meter, you will need to set the level manually, using the correction values shown in the image below. If you want to add 2 dB to the level, for example, just press +1 twice. Once you are fine with the level, click the **Next** button.

13. When using "Built-in Microphone" or free field calibration tool, and more than one speaker were selected, the procedure will continue automatically for other loudspeakers. If one or more frequencies cannot be calibrated, a warning will appear. At the end of the calibration a report will be displayed, showing any uncalibrated frequencies or levels.
14. Click **OK** to save the calibration and exit the **Loudspeaker Calibration** dialogue box.
15. By means of markings or fastening, make sure that the loudspeakers will be placed in this exact position compared to the client's location during testing.

You can import and export calibration data in the XML format using the **Import** and **Export** buttons correspondingly. After you click **Import**, locate the saved calibration XML file on your PC and click **Open**. Proceed to calibration afterwards. To export your calibration data, click the **Export** button and save the XML file to your local computer.

Use the **Print Report** button to print the calibration report.

8.10 Addition of External Sound Files for Speech Audiometry and Speech Mapping

To add a new media files folder:

1. On the **CD and Media Files Folders**, click **Add** button to add a new folder with your own sound files (wav, ogg, wma) or get the files from the Cloud. The **Custom Media files Folder** window opens.
2. Specify the **Name** of the external folder.
 - If you are planning on using the speech materials from the Cloud, activate the corresponding option.
3. Select the **Folder Path** where the external folder is located.
4. Select the **CD Scheme** that corresponds to your sound files and click the **Calibrate** button.
5. Select the track or special sound which will calibrate your sound files.
6. Calibrate the selected files and click **Save** button and then **OK** to save again.

The calibration of recently calibrated file will be used for all external sound files in Speech Mapping and Speech Audiometry modules.

Note: Only one calibration value is available and used for all external sound files and will be applied to all transducers.

8.11 Calibrating Speech CD Material

To adjust the output level for speech material:

1. Select **Settings** from the **Tools** menu.
2. In the **Settings** dialogue box, select **CD and Media Files Folders** from the General folder.
3. In **CD and Media Files Folders** Settings, click the button **Calibrate CD...** to open the **CD Calibration** window.
4. Adjust the CD Offset to the correct value in dB if the CD contains an offset value.

The value in the field “CD Offset” has only effect on the free field speakers, but not on the transducers. It will increase or decrease the common reference output level for the sound field speakers according to the value entered. A change of the offset value does not influence the VU meter level displayed.

Important Note: The required CD offset value should only be obtained in conjunction with a proper calibration equipment (sound level meter) to measure the output level of the sound field speaker.

Warning: Only recorded speech material with a stated relationship with the calibration signal should be used.

5. Select the calibration track on the CD and click **Start Calibration**.

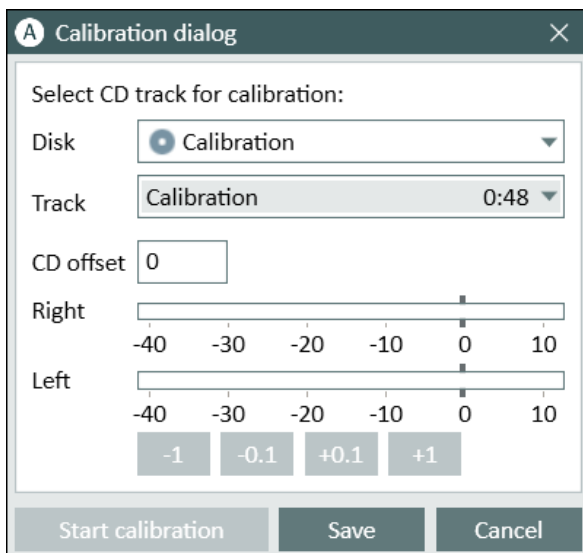

During the calibration adjust the level so the VU meter is around 0 using the ‘+’ and ‘-’ buttons.

6. Click **Save** to save the setting and exit the dialogue box.

8.12 Selecting Client and Entering Client Data

If client data has been saved in the Noah database, the client's name will appear in Noah's Patient Browser.

To start the program as a Noah module, you have to select the client in the Patient Browser and then click the software icon in the module list.

The application opens with the client's data displayed in the dashboard of the application.

If you need to create a client in Noah, open the Noah File menu, click **Add New Patient**, and then fill in the client data. Please note that fields marked in orange are mandatory.

If the application has been started outside the Noah system, you have to enter the client's data first. Open the **Tools** menu, click **Client Information**, and then fill in the client data.

Once you click **OK**, the client's name, date of birth and some other data will appear in the top title bar. To choose which information to display in the title bar, go to **Settings > General > Client Information** and select the appropriate checkboxes.

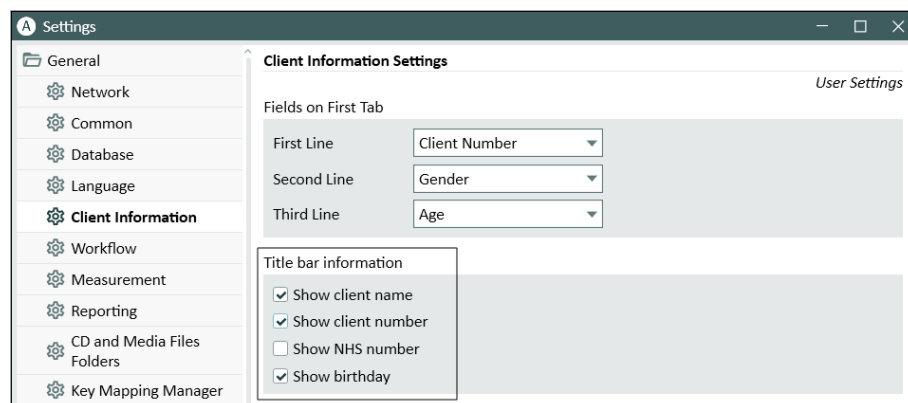

Alternatively, you can import client data that were previously exported from the application: open the **File** menu, click **Import Sessions** and then specify the location of the XML file with the client data.

8.13 Obtaining Hearing Threshold Levels

Prior to performing audiometric measurements with your client, please ensure the following:

For the client:

1. The client has a comfortable seating in the sound-attenuating booth.
2. The appropriate testing headsets are plugged into the appropriate sockets.
3. A client response switch is connected to the CLIENT RESPONSE socket of the Fitting Unit.
4. Optionally, a microphone for the client talk-back is connected to the TALK BACK MICROPHONE socket on the Fitting Unit.

For the operator:

1. Optionally, a monitor headset with boom microphone can be connected to the MONITOR HEADSET socket of the Fitting Unit for talk-back monitoring.
2. Optionally, a separate microphone is connected to the OPERATOR MICROPHONE socket for talk-over monitoring.

Click on the icon on the **Audiometry tasks** tab in the application to open the Audiometry front page in the dashboard.

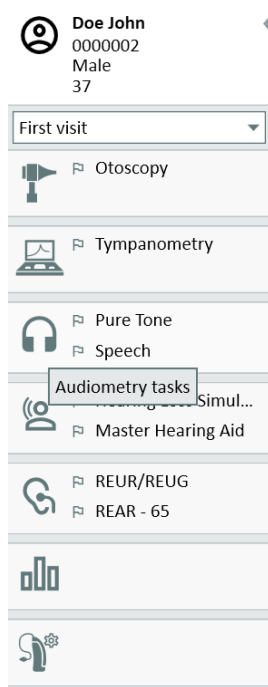

Click the **Pure Tone Measurement** button (**Pure Tone Measurement**) in the Audiometry pane of the dashboard to open the **Pure Tone Measurement** window.

Make sure that **HTL** is selected in the **Test Types** panel in the top left corner of the window.



To select the **HTL** test type, simply click it. Alternatively, you can press the **T** button on the keyboard.

Check the settings on the **Measurement Controls** panel below the audiograms:

1. Select ear by means of the blue (?) or red button (🔴). Alternatively, use the **L** button on the keyboard for the left ear and the **R** button for the right ear.
2. Set frequency and amplitude by means of the "+" and "-" buttons. Alternatively, use the arrow left/right and up/down buttons of the keyboard.
3. Configure the necessary masking settings.
4. If you need to adjust the talk-over/back levels, click the **Settings** (⚙️) button to open this setting menu.

For a complete list of keyboard shortcuts, please refer to the Help file. To open it, go to the Help menu of the application and click **Get Help**; alternatively, press **F1** on the keyboard.

Click the **Stimulus** button, or press the spacebar on the keyboard, to present a signal to the client. When the client is capable of catching the signal of a certain frequency and level, he or she responds by using the response switch. When this happens, the colour of the **Frequency Levels** pane changes.

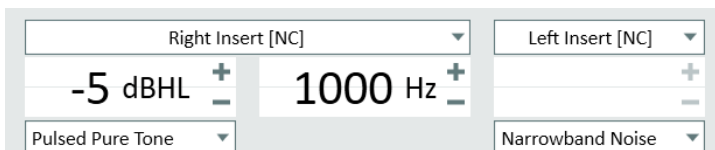

The screenshot shows the Measurement Controls panel with the following settings:

- Right Insert [NC]: [Dropdown]
- Left Insert [NC]: [Dropdown]
- Amplitude: -5 dBHL (with + and - buttons)
- Frequency: 1000 Hz (with + and - buttons)
- Stimulus type: Pulsed Pure Tone (with dropdown arrow)
- Masking type: Narrowband Noise (with dropdown arrow)

Click the **Store** button, or the **S** button on the keyboard, to mark the point in the audiogram.

Refer to the Help file for a detailed description of the procedure.

When you have obtained all required data for both ears, click **Save**—the button is active if the program is opened as a Noah module—and then **Close**, in order to save your measurement data.

After that, a corresponding item appears in the **Measurement History** pane of the dashboard. If you place the mouse pointer over the history item, the corresponding audiogram will be shown in a large format.

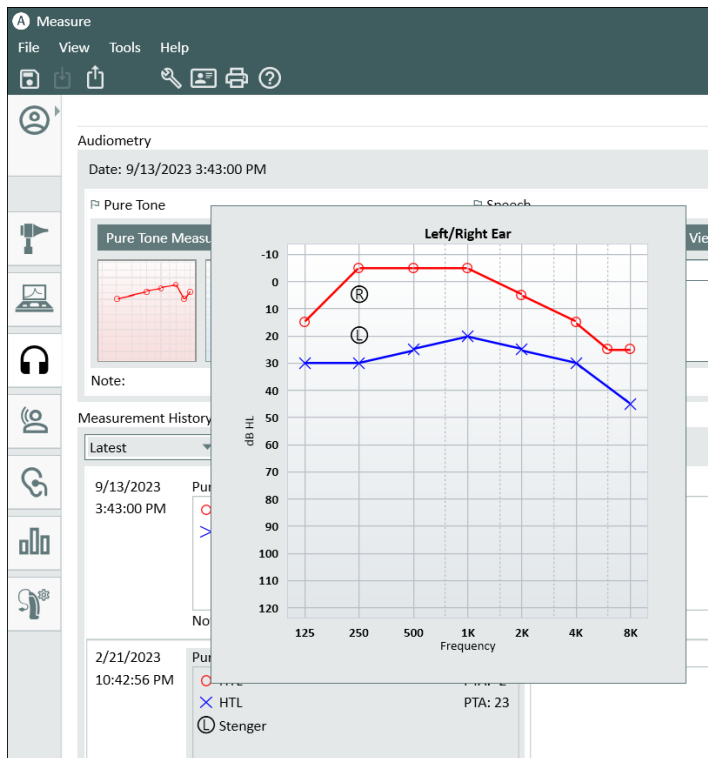

You can double click any measurement from the session list to display it in the workspace.

From the **Measurement History** pane, it is also possible to print a selected measurement by employing the corresponding button.

The **Print** option enables printing reports for the current or any of the older sessions. For REM, SM and HIT measurements, the only default report type will be printed. As for the Audiometry Reports, you can choose between a number of available options in the Print Options section that is accessible via **Settings > General > Reporting**.

8.14 Shutdown Procedure

Closing Application

To safely close the application:

1. Select **File > Exit** or use **Alt+F4**. If you made any measurements, the system will show the warning:

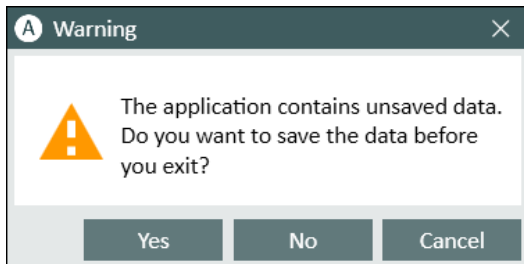

2. Click **Yes** to save the session data and close the application. Click **No** if you want to close the application without saving of data.

Disconnecting Fitting and HIT Units

For the Unit that uses the Opto-USB cable without power DC adapter: disconnect the USB cable from the instrument and the USB power supply from the mains power outlet.

For the Unit that uses DC adapter and non-optical USB: disconnect the USB cable from the instrument and then disconnect the DC adapter both from the instrument and the mains power outlet.

For the Unit that uses non-optical USB without power DC adapter: disconnect the USB cable from the instrument.

For the Unit that uses the Opto-USB cable and power DC adapter: disconnect the USB cable and the USB power supply from the mains outlet and then the power DC adapter from the instrument and the mains power outlet.

9 Maintenance

9.1 Annual Calibration of Headset and Transducers

The headset and transducers delivered with the Fitting System and reference and coupler microphones delivered with the HIT Unit are NOT intended for calibration by users. Contact your local distributor for your annual service and calibration.

9.2 Adjustment of Common Headsets and Microphones

All calibration of the Fitting System and transducers delivered with the system has been made by the manufacturer before shipment. The system's accessories should be re-calibrated

annually by the supplier or their appointed representatives to ensure system integrity.

Depending on your license agreement, however, you may have access to perform calibrations locally. In this case some extra options, like Headphones Calibration, REM Calibration, and HIT Microphone Calibration, can be done with a separate calibration tool.

9.3 Regular System Checks

9.3.1 Adjusting Speech Audiometer input level

Prior to speech testing, it is recommended to check the VU-meter for proper sensitivity level. For this, you should play a CD calibration signal and adjust the input sensitivity to 0 dBVU.

9.3.2 Calibration of probe tube and reference microphone (in REM and SM)

Prior to real ear measurement session or when replacing the probe tube with a new one, ensure the correct probe tube calibration. If it is calibrated properly, you should see a flat curve once measuring a REUG with the probe tube still kept in the calibration position.

9.3.3 HIT box calibration

On a regular basis (e.g. once per day), check the proper coupler microphone sensitivity and calibration. The procedure is as follows:

1. Unscrew the coupler microphone body to expose the coupler microphone diaphragm.
2. Place it close against reference microphone without it touching.
3. Conduct an OSPL90 measurement, you should see a flat line at 90 dB.

9.4 Inspection

On a regular basis, that is, at least once a week, perform a visual inspection of the Fitting and HIT Units and their accessories for visible damages. During use, evaluate the test results and perform a system inspection if the results appear unreliable.

9.5 Cleaning

9.5.1 Disposable parts

 Parts such as foam tips on insert earphones or probe tubes for real-ear measurement are not intended for reuse. Dispose of such items in a hygienic manner after each client session.

9.5.2 Reusable parts

Maintain a high level of hygiene and clean reusable devices which come into contact with clients between each use. See the cleaning instructions below.

9.5.3 Cleaning instructions

- For cleaning use only a soft dry cloth dampened very sparingly with a low level disinfectant solution such as isopropyl alcohol to wipe the device. Do not allow excess solution to enter the device as this may damage internal components.
- Do not autoclave, pressure sterilise, or gas sterilise the device or any of its electrical accessories.
- Do not soak or immerse the device in any liquid.
- Do not use acetone or paraffin/kerosene-based solutions, or any other harsh solvent to clean the device or its accessories. Use of such substances may be harmful to the equipment and may result in faulty operation.

9.6 Switching to a new transducer

When setting up a new transducer, make sure that it is recognized by the Fitting Unit. To do so, follow the instructions:

1. Connect the Fitting Unit to the PC using the USB cable.
2. Start Measure.
3. Wait until the Fitting Unit is initialized and connected. The current connection status is displayed on the right side of the status bar at the bottom of the screen.
4. Disconnect the old transducer.
5. Connect the new transducer to the Fitting Unit.
6. In Measure, go to **Tools > Device Management**.
7. Review the name and serial number of the new transducer.

If the data corresponds to the new transducer, you can start using the system normally.

If the data corresponds to the old transducer, proceed with the next steps.

8. In Measure, go to **Tools > Refresh Transducer Data**.
9. Select the needed transducer and click **Refresh Transducer Data**.
10. The system will inform you once the process is finished. You can close the window and start using the system normally.

10 Troubleshooting Guide

If you have any problems with installing or running the software, please go through this guide first before contacting a Support/HOT-line.

Please verify that the following installation prerequisites are satisfied:

- The Fitting System software supports Windows 10, Windows 10 Anniversary Update and Windows 11 operating systems.
- Local administrator rights are required in Windows to install the Fitting System software.
- The Fitting System software supports NOAH 4 or higher.

Before starting the troubleshooting – please ensure that you do the following steps:

- Unplug the USB cables and power supply (if available) from the Fitting/HIT unit.
- Re-start the computer.
- Connect the Fitting/HIT unit to the computer using the USB cable.
- Connect the power supply to the Fitting/HIT unit, if available.
- Check that all available headsets, speaker and other accessories are connected to the Fitting/HIT unit.
- Run the Fitting System software.
- Check that the Fitting/HIT unit is connected properly:



- Power light on the Fitting/HIT unit is permanently on.

If any of the above steps failed, please refer to the below table for the solution of your problem.

Problem	Action
Software installation problems	
<ul style="list-style-type: none"> • Setup can't be completed successfully (when running the setup_x.x.x.x.exe). 	<ul style="list-style-type: none"> • Use only the supported Windows operating systems. • Use the latest Windows service packs.
Software set-up problems	
<ul style="list-style-type: none"> • The stimulus button in the Audiogram is greyed out. • At start-up of the Fitting System the "License notification" message is shown. 	<ul style="list-style-type: none"> • The License code is not activated. Please activate the license from the help menu and follow the description for the activation of the license code.
Hardware connection problems	
<ul style="list-style-type: none"> • In the Fitting Software System's status bar under 	<ul style="list-style-type: none"> • Reconnect a USB cable and power supply, if available. Check that the units are connected. (See

Problem	Action
<p>“AUD HW/ HIT HW” it says: “Not connected”.</p>	<p>the status bar in the software).</p> <ul style="list-style-type: none"> • Try another USB port on the computer. • Try another USB cable. • If connection is done via hub/switch, connect directly to computer.
<ul style="list-style-type: none"> • No sound in headset or speakers, etc. 	<ul style="list-style-type: none"> • Ensure that the unit is connected to the computer using the USB cable. • Power light is steady on. • Plug and unplug all headsets. • Reconnect USB cable and power supply, if available. Check that the units are connected. (See the status bar in the software).
<ul style="list-style-type: none"> • No output from the speaker in REM. 	<p>Ensure that you have selected the correct speaker in the Tools > Settings > General > Loudspeaker selection > REM. Then calibrate your REM probe tube.</p>
<ul style="list-style-type: none"> • Power light is not steady at start-up of the Fitting Software System. 	<ul style="list-style-type: none"> • Re-start the Fitting Software System. • Reconnect USB cable and power supply, if available. Check that the unit is connected. (See the status bar in the software). • Check that the unit is displayed in Windows device manager under sound devices. If not, please contact support.

11 Hotline and Technical Support

Auditdata A/S, Wildersgade 10B, 1408 Copenhagen, Denmark. Phone +45 70 20 31 24
support@auditdata.com

UK Responsible Person:

Auditdata Ltd., Staines-upon-Thames, UK. Phone +44 (0) 333 4444 212.
support@auditdata.com

Australia Sponsor:

Daryl Staley-Jackson, 247 Creek Ridge Road, Glossodia, NSW, 2756, Australia.
support@auditdata.com

US:

Auditdata, LLC, 88 Glocker Way, #352 Pottstown, PA 19465. support@auditdata.com

Appendix A

A.1 Declarations of Conformity

Primus Fitting Unit+ (PFU+)

Auditdata

DECLARATION OF CONFORMITY

REGULATION (EU) 2017/745 OF THE EUROPEAN PARLIAMENT

Manufacturer name and address	Auditdata A/S Wildersgade 10B 1408 Copenhagen Denmark	
Notified Body name and address	TÜV SÜD Product Service GmbH Ridlerstrasse 65 80339 München	 0123
Product Identification	MD Category:	Hearing Medical Diagnostic (Hardware and Software)
	Trademark:	Primus PFU+
	Type/Model:	Primus Fitting Unit - PFU+ (PFU+)
	CS (Common specification)	N/A no common specification has been published
	SRN:	DK-MF-000011415
	Basic UDI/DI:	05711781DHF2000ZC
	Risk class:	Ila, rule 10
	Lot/Batches/Serial number:	All issued serial numbers from 21000001
Intended purpose	Audiometer is a device used for evaluating hearing acuity. The audiometer records the subject's responses to produce an audiogram of threshold sensitivity, or speech understanding profile. Audiometer with stated accessories is indicated for non-continuous, noninvasive air and optionally bone conduction and speech audiometric testing. Audiometer is indicated for non-continuous real-ear measurements (REM) at the ear drum by means of noninvasive external ear canal insertion of a probe tube.	
Conformity assessment	Annex IX (Quality system and technical documentation assessment)	
EC-Certificate No.:	G10 076081 0015	
DOC valid until	2029-02-18	

ID: 30.0109/22

This declaration of conformity is issued under the sole responsibility of Auditdata A/S. We hereby declare that the medical device specified above is in conformity with the European Regulation (EU) 2017/745 and Directive 2011/65/EU.

Copenhagen, February 19th 2024

Denys Lebedev, QA/RA Manager



2000 Primus HIT Pro

Auditdata

DECLARATION OF CONFORMITY

REGULATION (EU) 2017/745 OF THE EUROPEAN PARLIAMENT

Manufacturer name and address	Auditdata A/S Wildersgade 10B 1408 Copenhagen Denmark	
Notified Body name and address	Danish Health and Medicines Authority Axel Heides Gade 1 2300 Copenhagen S, Denmark	
Product Identification	MD Category: Trademark: Type/Model: CS (Common specification) SRN: Basic UDI/DI: Risk class: Lot/Batches/Serial number:	Hearing Medical Diagnostic (Hardware) Primus HIT 2000 Primus HIT Pro (Unit), 2005 -1 HIT Unit N/A no common specification has been published DK-MF-000011415 05711781DHF2000ZC I, rule 13 All issued serial numbers from 32000001
Intended purpose	The HIT Unit is intended to apply sound to the hearing aid in a closed test box and obtain the acoustical output of the hearing aid in a coupler cavity equipped with a microphone. The HIT Unit is intended to be used together with the Software to provide objective indication of the characteristics of a Hearing Aid. Visualization of the obtained coupler microphone signal is only available in the Software application. The HIT Unit is indicated for technical quality inspection or fitting of hearing instruments with no clients involved.	
Conformity assessment	Annex I, II and III	

This declaration of conformity is issued under the sole responsibility of Auditdata A/S. We hereby declare that the medical device specified above is in conformity with the European Regulation (EU) 2017/745 and Directive 2011/65/EU.

Copenhagen, May 26th 2024

Denys Lebedev, QA/RA Manager



ID: DND0095/05

2000 Primus Fitting Unit Pro

Auditdata

DECLARATION OF CONFORMITY

REGULATION (EU) 2017/745 OF THE EUROPEAN PARLIAMENT

Manufacturer name and address	Auditdata A/S Wildersgade 10B 1408 Copenhagen Denmark	
Notified Body name and address	TÜV SÜD Product Service GmbH Ridlerstrasse 65 80339 München	 0123
Product Identification	MD Category: Trademark: Type/Model: CS (Common specification) SRN: Basic UDI/DI: Risk class: Lot/Batches/Serial number:	Hearing Medical Diagnostic (Hardware and Software) Primus Pro Primus Fitting Unit Pro (2000 Primus Fitting Unit Pro, PFU Pro) N/A no common specification has been published DK-MF-000011415 05711781DHF2000ZC IIa, rule 10 All issued serial numbers from 25000001
Intended purpose	Audiometer is a device used for evaluating hearing acuity. The audiometer records the subject's responses to produce an audiogram of threshold sensitivity, or speech understanding profile. Audiometer with stated accessories is indicated for non-continuous, noninvasive air and optionally bone conduction and speech audiometric testing. Audiometer is indicated for non-continuous real-ear measurements (REM) at the ear drum by means of noninvasive external ear canal insertion of a probe tube.	
Conformity assessment	Annex IX (Quality system and technical documentation assessment)	
EC-Certificate No.:	G10 076081 0015	
DOC valid until	2029-02-18	

ID: DM01781/02

This declaration of conformity is issued under the sole responsibility of Auditdata A/S. We hereby declare that the medical device specified above is in conformity with the European Regulation (EU) 2017/745 and Directive 2011/65/EU.

Copenhagen, February 19th 2024

Denys Lebedev, QA/RA Manager



2000 Primus Audiometer Unit Ice

Auditdata

DECLARATION OF CONFORMITY

REGULATION (EU) 2017/745 OF THE EUROPEAN PARLIAMENT

Manufacturer name and address	Auditdata A/S Wildersgade 10B 1408 Copenhagen Denmark	
Notified Body name and address	TÜV SÜD Product Service GmbH Ridlerstrasse 65 80339 München	 0123
Product Identification	MD Category: Hearing Medical Diagnostic (Hardware and Software) Trademark: Primus Ice Type/Model: 2000 Primus Audiometer Unit Ice CS (Common specification) N/A no common specification has been published SRN: DK-MF-000011415 Basic UDI/DI: 05711781DHF2000ZC Risk class: IIa, rule 10 Lot/Batches/Serial number: All issued serial numbers from 26000001	
Intended purpose	Audiometer is a device used for evaluating hearing acuity. The audiometer records the subject's responses to produce an audiogram of threshold sensitivity, or speech understanding profile. Audiometer with stated accessories is indicated for non-continuous, noninvasive air and optionally bone conduction and speech audiometric testing.	
Conformity assessment	Annex IX (Quality system and technical documentation assessment)	
EC-Certificate No.:	G10 076081 0015	
DOC valid until	2029-02-18	

This declaration of conformity is issued under the sole responsibility of Auditdata A/S. We hereby declare that the medical device specified above is in conformity with the European Regulation (EU) 2017/745 and Directive 2011/65/EU.

Copenhagen, February 19th 2024

Denys Lebedev, QA/RA Manager



ID: DMC0623/07

2000-1 Fitting Unit

Auditdata DECLARATION OF CONFORMITY

REGULATION (EU) 2017/745 OF THE EUROPEAN PARLIAMENT

Manufacturer name and address	Auditdata A/S Wildersgade 10B 1408 Copenhagen Denmark	
Notified Body name and address	TÜV SÜD Product Service GmbH Ridlerstrasse 65 80339 München	 0123
Product Identification	MD Category: Trademark: Type/Model: CS (Common specification)	Hearing Medical Diagnostic (Hardware and Software) Measure, Unity 4 2000-1 Fitting Unit (2000-1 FU) N/A no common specification has been published
Intended purpose	SRN: DK-MF-000011415 Basic UDI-DI: 05711781DHF2000ZC Risk class: IIa, rule 10 Lot/Batches/Serial number: All issued serial numbers for 2000-1 FU from 33000001	
Conformity assessment	Annex IX (Quality system and technical documentation assessment)	
EC-Certificate No.:	G10 076081 0015	
DOC valid until	2029-02-18	

ID: DND2475/02

This declaration of conformity is issued under the sole responsibility of Auditdata A/S. We hereby declare that the medical device specified above is in conformity with the European Regulation (EU) 2017/745 and Directive 2011/65/EU.

Copenhagen, February 19th 2024

Denys Lebedev, QA/RA Manager



A.2 Manufacturer



The Fitting System is manufactured and sold in the EU by:

Auditdata A/S

Wildersgade 10B
1408, Copenhagen
Denmark
Phone: +45 70203124

www.auditdata.com



PRIMUS FITTING UNIT+ (PFU+)

2000 PRIMUS HIT PRO

2000 PRIMUS FITTING UNIT PRO

2000 PRIMUS AUDIOMETER UNIT ICE

2000-1 FITTING UNIT

A.3 Labelling

Label samples

Measure

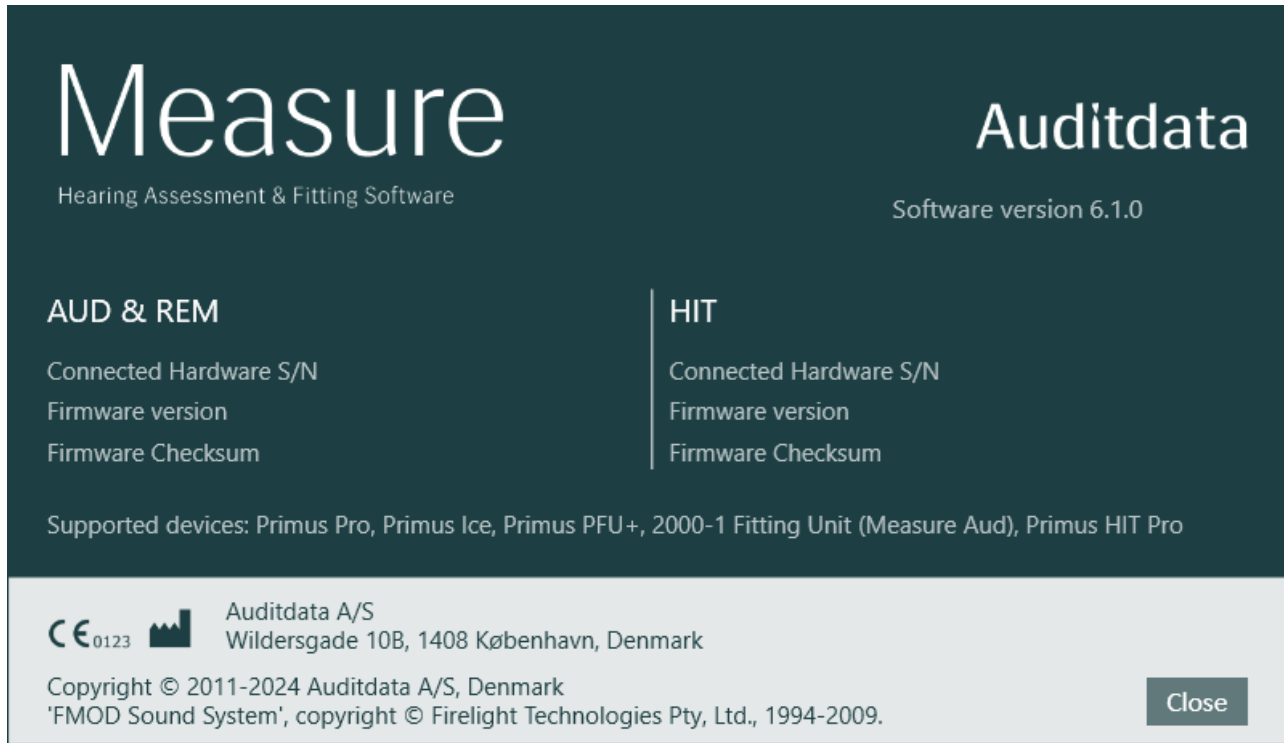

The screenshot shows the 'Measure' software interface. The title 'Measure' is prominently displayed on the left, with the subtitle 'Hearing Assessment & Fitting Software' below it. On the right, the 'Auditdata' logo is shown, along with the text 'Software version 6.1.0'. The interface is divided into two main sections: 'AUD & REM' and 'HIT'. Each section lists 'Connected Hardware S/N', 'Firmware version', and 'Firmware Checksum'. Below these sections, a line of text reads: 'Supported devices: Primus Pro, Primus Ice, Primus PFU+, 2000-1 Fitting Unit (Measure Aud), Primus HIT Pro'. At the bottom of the window, there is a footer area containing the CE mark, the Auditdata A/S logo, the company name 'Auditdata A/S', the address 'Wildersgade 10B, 1408 København, Denmark', and copyright information: 'Copyright © 2011-2024 Auditdata A/S, Denmark' and 'FMOD Sound System', copyright © Firelight Technologies Pty, Ltd., 1994-2009. A 'Close' button is located in the bottom right corner of the footer area.

Measure
Hearing Assessment & Fitting Software

Auditdata
Software version 6.1.0

AUD & REM

- Connected Hardware S/N
- Firmware version
- Firmware Checksum

HIT

- Connected Hardware S/N
- Firmware version
- Firmware Checksum

Supported devices: Primus Pro, Primus Ice, Primus PFU+, 2000-1 Fitting Unit (Measure Aud), Primus HIT Pro

CE 0123  Auditdata A/S
Wildersgade 10B, 1408 København, Denmark



Copyright © 2011-2024 Auditdata A/S, Denmark
'FMOD Sound System', copyright © Firelight Technologies Pty, Ltd., 1994-2009.

Close



Appendix B



B.1 Technical Specification

B.1.1 Fitting Unit

Item	Description	Value
Mechanical Data:		
Primus Fitting Unit, without cover	External measures L x W x H Weight	345 x 110 x 35 mm 475 g
Primus Pro, without cover	External measures L x W x H Weight	345 x 112 x 35 mm 500 g
Primus Ice, without cover	External measures L x W x H Weight	167 x 110 x 32 mm 375 g
Primus Fitting Unit, with cover	External measures L x W x H Weight	350 x 120 x 130 mm 800 g
Primus Pro, with cover	External measures L x W x H Weight	360 x 120 x 96 mm 900 g
Primus Ice, with cover	External measures L x W x H Weight	181 x 115 x 94 mm 550 g
2000-1 FU	External measures L x W x H Weight	142 x 142 x 55 mm 415 g
Electrical Data:		
 Power supply, low power output	5 volts USB power	max 500 mA
 Provided power supplies for USB power in conjunction with OPTO USB cable (Type OPTICIS M2-100-03)	type Friwo FW7662M/05	Input voltage 100-240 V, 50/60 Hz, 150 mA; output voltage 5 Vdc, 1.1 A
	type Friwo FW8002M/05	Input rated 100-240 V ±10%, 50/60 Hz, 160 mA. Output rated 5 Vdc, 1.4 A
 Provided power supplies for USB power in conjunction with USB isolation cable Type IF-TOOLS; ISOUSB-BOX-PLUS; Art. No.: 14000	The USB Isolator has internal power supply.	Output voltage 5 Vdc, 0.5 A

Item	Description	Value
 Provided power supplies for high power output functionality	Direct plug-in power supply, type Friwo FW7362M/15	Input voltage 100-240 V AC, 50/60 Hz, 700 mA; output voltage 15 Vdc, 2.0 A
	Direct plug-in power supply, type Friwo FW8030M/15	Input rated 100-240 V ±10%, 50/60 Hz, 300 mA. Output rated 15 Vdc, 2.0 A
Free-field output	w/overload protection	2 channels, each up to 20 watts in 4 ohms *1*4*5 3 channels, each up to 20 watts in 4 ohms *2*3
Left/Right, Sub/Mid, Rear Free Field Line Out *1*2 Line Out 1/Line Out 2/Line Out 3 - Free Field Line Out *3 Line Out/Demo Headset *4 Line Out *5	500 mV RMS	max load 16 ohms
Client*1*2/Demo*3 and Monitor Headset output	500 mV RMS	max load 16 ohms
Operator microphone	Electret microphone powered inputs	-40 dB+/-5 dB (0 dB = 1 V/pa, 1000 Hz)
Talk back microphone	Electret microphone powered inputs	-55 dB+/-4 dB (0 dB = 1 V/pa, 1000 Hz)
REM Probe input	Electret microphone powered inputs	Refer to sec. B.2.2
Air and Bone Conductor Outputs	For Tone and Speech: 3 Vrms (w. external power supply) 1 Vrms (USB only) 125 Hz – 16 kHz Frequency Range Range For Bone Conductor: 250 Hz - 8kHz Frequency Range	Max load 4 ohm
Calibration	Refer to a separate manual for	

Item	Description	Value
	calibration instructions. Tone and Speech signals are calibrated for Max Hearing Level Tolerance: +/- 3 dB (up to 8 kHz) +/-5 dB (8 kHz and higher) Masking signals are calibrated for Max Sound Pressure Level	
Client response button	Normally open contact	
Fuses	Autofuses	
Environmental Data:		
Warm-up time	(if stored at room temperature)	1 minute
Operating temperature		5 °C – 40 °C
Storage temperature		-30 °C - 70 °C
Humidity		5% - 90%
Air pressure (altitude)		70 kPa (3000 meter) to 106 kPa (-400 meter)
Connectors:		
 DC power		Pin 2.5 mm/Hole 7.0 mm Pin: positive supply (+) Ring: negative supply (-)
 USB 2.0 and USB 3.0	Complies with 60601-1 3 rd or IEC 60950-1	USB-B*1*2*3*4 USB-C*5
S/PDIF*3*5	Optical Audio	TOSLINK connector*3 Optical Mini Jack 3.5 mm*5
Left speaker/Middle speaker/Right speaker	Anitek, H5-02-1-0-5-0	2 pcs*4*5 3 pcs*1*2*3
Line Out 1/Line Out 2/Line Out 3 - Free Field Line Out*3 Left/Right, Sub/Mid, Rear Free Field Line Out*1*2 Line Out/Demo Headset*4 Line Out*5	Stereo mini jack	3.5 mm
Operator and talk back	Stereo mini jack	3.5 mm

Item	Description	Value
microphone input		
Client* ¹ * ² /Demo* ³ and Monitor Headset output	Stereo mini jack	3.5 mm
Air conductor 1 * ¹ * ² * ³ * ⁴	DIN	8 pin
Air conductor* ⁵	Mini-DIN	8 pin
Air conductor 2* ¹ * ² * ³	DIN	8 pin
Air conductor HF* ⁵	Mini-DIN	8 pin
Air conductor 3 (high frequency)* ¹ * ² * ³	DIN	8 pin
Bone conductor * ¹ * ² * ³ * ⁴	DIN	8 pin
Bone conductor* ⁵	Mini-DIN	8 pin
Client response* ¹ * ² * ³ * ⁴	DIN	8 pin
Client response* ⁵	Mini-DIN	8 pin
Option* ² * ³	DIN	8 pin
Option* ⁵	Mini-DIN	8 pin
Probe* ¹ /Real Ear Probe* ² * ³ input	DIN	8 pin
REM Probe* ⁵	Mini-DIN	8 pin
Parts and Accessories*:	Description	
AUD (in Fitting Unit)	Clinical audiometer	
REM (in Fitting Unit)	Real ear measurement unit	
Speech Mapping	Speech Mapping with Live voice and Percentile Analysis	
 AUD/REM DC adaptor	15 volts/2A	
 Optical USB connection	Type OPTICIS M2-100-03 Type IF-TOOLS; ISOUSB-BOX-PLUS; Art. No.: 14000	
Headset with microphone	Monitor headset w/boom microphone for operator monitoring and talk over	
Headset without microphone	Monitor headset	
Microphone	Table microphone for talk over or talk back	

Item	Description	Value
Extension cord for sound attenuating booth		
Loudspeaker incl. cable	Free-field loudspeaker for real ear measurement and audiometry	
Insert Earphones	Audiometric insert earphones	
Ear tips (small)	Insert ear tips for Primus Insert – small (children)	
Ear tips (medium)	Insert ear tips for Primus Insert – medium	
Ear tips (large)	Insert ear tips for Primus Insert – large	
Insert tube with nipples	For the Insert earphones only. Length 200 mm	
Probe tube guide	Probe tube stabilizer	

- *¹ Only available in the PFU.
- *² Only available in the PFU+.
- *³ Only available in Primus Pro.
- *⁴ Only available in the Primus Ice.
- *⁵ Only available in the 2000-1 Fitting Unit.

Applied Parts Type B





Note: These parts must only be replaced by identical parts delivered by the manufacturer.

Item	Description
Insert Phone/Insert Earphone Flex	Real Ear audiometric insert earphones (Model: Realear)
ER-3A Insert Headset	EarTone audiometric insert earphones (Model: EarTone 3A)
ER-3C Insert Headset	Etymotic audiometric insert earphones (Model: Etymotic Research type 3C)
TDH-39 Headset	Supraaural audiometric headphone
HDA-200 Headset	Sennheiser circumaural audiometric high frequency headphone
HDA-280 Headset	Sennheiser standard audiometric headphone

Item	Description
HDA-300 Headset	Sennheiser circumaural audiometric high frequency headphone
DD45 Headset	Interacoustics supraaural audiometric headphone
DD450 Headset	RadioEar circumaural audiometric high frequency headphone
DD65 Headset	Interacoustics circumaural audiometric headphone
DD65v2 Headset	RadioEar circumaural audiometric headphone
B-71 Bone Conductor	RadioEar audiometric bone conductor
Client response button	Single-button response switch
Free field calibration tool	Free field calibration microphone
Real Ear Probe/REM Probe Flex	REM Probe, binaural real-ear measurement probe set

*) **Note:** The list of Parts and Accessories is subject to change without notice.

B.1.2 HIT - Hearing Instrument Test Unit

Item	Description	Value
Indoor use		
Mechanical Data:		
Hearing Instrument Test Unit	External measures L x W x H	350 x 320 x 125 mm
Weight		4.5 kgs
Electrical Data:		
Power supply, low power	5 volts USB power	max 500 mA
 Provided power supplies for USB power in conjunction with OPTO USB cable (Type OPTICIS M2-100-03)	type Friwo FW7662M/05	Input voltage 100-240 V, 50/60 Hz, 150 mA; output voltage 5 Vdc, 1.1 A
	type Friwo FW8002M/05	Input rated 100-240 ±10%, 50-60Hz, 160 mA. Output rated 5Vdc, 1.4 A.
 Provided power supplies for USB power in conjunction with USB isolation cable Type IF-TOOLS; ISOUSB-BOX-PLUS; Art. No.: 14000	The USB Isolator has internal power supply.	Output voltage 5 Vdc, 0.5 A
 Provided power supplies for high power output functionality	Direct plug-in power supply, type Friwo FW7362M/15	Input voltage 100-240 V AC, 50/60 Hz, 700 mA; output voltage 15 Vdc, 2.0 A
	Direct plug-in power supply,	Input rated 100-240 ±10%,

Item	Description	Value
	type Friwo FW8030M/15	50-60Hz, 300 mA. Output rated 15Vdc, 2.0 A
MAINS supply voltage fluctuations		up to ±10 % of the nominal voltage
TRANSIENT OVERVOLTAGES		up to the levels of OVERVOLTAGE CATEGORY II; NOTE 1 These levels of transient overvoltage are typical for equipment supplied from the building wiring.
TEMPORARY OVERVOLTAGES occurring on the MAINS supply		2 500 V impulse withstand voltage
Free-field output	w/overload protection	up to 20 watts in 4 ohms
Fuses	Autofuses	
Environmental Data:		
Warm-up time	(if stored at room temperature)	1 minute
Operating temperature		5 °C – 40 °C
Storage temperature		-30 °C - 70 °C
Humidity		5% - 90%
Air pressure (altitude)		70 kPa (3000 meter) to 106 kPa (-400 meter)
Applicable POLLUTION DEGREE of the intended environment		POLLUTION DEGREE 2 in most cases
Connectors:		
 DC power		Pin 2.5mm/hole 7.0mm Pin: positive supply (+) Ring: negative supply (-)
USB 2.0 and USB 3.0	Complies with 60601-1 3 rd or IEC 60950-1	USB-B
Left HI-PRO or NOAHlink™ input	6 pin mini DIN	

Item	Description	Value
Right HI-PRO or NOAHlink™ input	6 pin mini DIN	
Monitor headset	Stereo mini jack	3.5mm
Parts and Accessories*:	Description	
Reference microphone	Installed, Electret goose neck type	
Coupler microphone	Installed, Electret type	
Coupler	2 cc coupler with attachments for ITE, BTE, and Body-worn Hearing Instruments	
Battery pills, 5 sizes	Type 5A, 10A, 312, 13 and 675	
BTE tube	PVC tube for BTE Hearing Instruments. Length 25 mm	
ITE putty	Putty for fastening of ITE Hearing Instruments to the ITE coupler	

*) **Note:** The list of Parts and Accessories is subject to change without notice. An updated list will always be available from our homepage: www.auditdata.com.

B.2 Technical Data

B.2.1 AUD system

No. of channels:	Full 2 channel
Tone presentation:	Steady, pulsed
Signal types:	Pure Tone: IEC 60645-3:2007 125 Hz - 16 kHz* Accuracy within 0.2% Modulated Tone: 125 Hz – 8 kHz Triangular linear 10.8 Hz Repetition Rate +/-10% Frequency Deviation (of carrier frequency)
Masking types:	Narrow Band Noise: IEC 60645-1, 1/3 Octave

	<p>filter with geometric center frequency as the audiometric TONE frequency</p> <p>White Noise: 100-20000 Hz with +3 dB/octave throughout its frequency range</p> <p>Speech-weighted: IEC 60645, 125-1000 Hz +3 dB/octave , 1000-6000 Hz - 9 dB/octave</p> <p>Pink Noise: 100-20000 Hz, +/-1 dB throughout its frequency range</p>
Hearing levels:	-10 dB - 120 dB HL
Deviation, dB:	0.5 dB
Distortion:	<p>Less than 3 % for air conduction.</p> <p>Less than 6% for bone conduction.</p>

* Primus Ice supports 125 Hz - 8 kHz only.

B.2.2 REM system

No. of channels:	4 channel (2 probe microphone units with each a reference mic. and a probe mic.)
Signal types:	<p>White noise, speech-weighted noise, and pink noise.</p> <p>For technical specifications refer to section B.2.1.</p>
Further Signals:	<p>ISTS Signal according to IEC 60118-15,</p> <p>Crest factor: 17</p> <p>ISTS MPO signal</p> <p>Peak-Level: 90dB</p> <p>SPL Frequencies: 0,5, 1, 2, 3, 4 kHz</p>

	<p>On time: 250 ms Off time: 250 ms Rise- and fall time: 25 ms ICRA Signals: (Hearing Aid Clinical Test Environment Standardization) DSL Signals: Female “S” and “SH” (Child Amplification Laboratory National Centre for Audiology Western University London, Ontario)</p>
Frequency range:	125 Hz – 16 kHz
Signal levels:	50 – 90 dB SPL
Accuracy:	Within 4 dB
Signal Analysis:	<p>Analysis type: FFT Analysis bandwidth: 125 Hz to 16 kHz Resolution: 24 bands/Octave Windowing type: Hann</p>
Equalization type:	Modified pressure method
Sensitivity, Probe Mic.	<p>Depending on selected input range, 10 ranges available -35 dB (0 dB = 1 V/pa, 1000 Hz)</p>
Sensitivity, Reference Mic.	<p>Depending on selected input range, 6 ranges available -35 dB (0 dB = 1 V/pa, 1000 Hz)</p>
Measurement Range	40 dB SPL to 100 dB SPL

B.2.3 HIT system

No. of channels:	2 channel - One coupler microphone and one reference microphone
Signal types:	Pure tone, modulated tone, narrowband noise, white

	noise, speech-weighted noise, and pink noise. For technical specifications refer to section B.2.1.
Frequency range:	200 Hz – 16 kHz
Signal levels:	40 – 100 dB SPL
Tolerance, dB:	+/- 1,5 dB in the frequency range 200 - 2000 Hz and +/- 2,5 dB in the frequency range 2000 - 5000 Hz and above.
Pure tone accuracy:	+/-2%
Distortion:	Less than 0,5% at 70 dB. Less than 2% at 90 dB.

B.2.4 Insert Phone/Insert Earphone Flex

Insert Phone/Insert Earphone Flex	Including Audiometric insert earphones
Frequency range:	125 Hz to 8 kHz
Maximum output level:	Up to 120 dB HL at mid frequencies
Compliance:	EN 60645 and ISO 389-2

B.2.5 Real Ear Probe/REM Probe Flex

Real Ear Probe/REM Probe Flex	Adjustable left and right-ear hangers, each with reference and probe tube microphone
Frequency range:	125 Hz to 16 kHz
Maximum input level for probe tube input:	125 dB SPL with less than 3% distortion. Up to 135 dB SPL

B.3 EMC Conformance Requirements

B.3.1 EMC Classification, Standards and Test Methods

Emissions:	EN 55011/CISPR11, Group 1, Class B
Harmonic Current Emission:	IEC 61000-3-2:2018, Class A
Voltage Fluctuations and Flicker:	IEC 61000-3-3:2013

Immunity:	Test levels for professional healthcare environment.
Enclosure Port:	
Basic EMC standard	Immunity test level
IEC 61000-4-2 (ESD)	± 8 kV contact, ± 2 kV, ± 4 kV, ± 8 kV, ± 15 kV air
IEC 61000-4-3 (rad. Fields)	3 V/m, 80 MHz – 2,7 GHz, 80 % AM at 1 kHz & Test points / frequencies according to table 9 of IEC/EN 60601-1-2 (RF wireless communications equipment): 385 MHz; Pulse Modulation: 18 Hz; 27 V/m 450 MHz, FM + 5Hz deviation: 1 kHz sine; 28 V/m 710, 745, 780 MHz; Pulse Modulation: 217 Hz; 9 V/m 810, 870, 930 MHz; Pulse Modulation: 18 Hz; 28 V/m 1720, 1845, 1970 MHz; Pulse Mod.: 217 Hz; 28 V/m 2450 MHz; Pulse Modulation: 217 Hz; 28 V/m; 5240, 5500, 5785 MHz; Pulse Mod.: 217 Hz; 9 V/m
IEC 61000-4-8 (magn. Fields)	30 A/m, 50 Hz & 60 Hz
Input a.c. Power Port:	
Basic EMC standard	Immunity test level
IEC 61000-4-4 (bursts)	± 2 kV, 100 kHz repetition frequency
IEC 61000-4-5 (surges)	$\pm 0,5$ kV, ± 1 kV, line to line
IEC 61000-4-6 (cond. RF)	3 V/m, 0,15 MHz – 80 MHz, 80 % AM at 1 kHz 6 V/m in ISM bands between 0,15 MHz and 80 MHz
IEC 61000-4-11 (volt. dips)	0 % UT; 0,5 cycle at 0°, 45°, 90°, 135°, 180°, 225°, 270° and 315°. 0 % UT; 1 cycle and 70 % UT; 25/30 cycles at 0°
IEC 61000-4-11 (volt. inter.)	0 % UT; 250/300 cycle
Patient Coupling Port: Device has no patient coupling port	
Signal Input / Output Port:	
Basic EMC standard	Immunity test level
IEC 61000-4-2 (ESD)	± 8 kV contact, ± 2 kV, ± 4 kV, ± 8 kV, ± 15 kV air
IEC 61000-4-4 (bursts)	Only applicable for patient headsets, patient client

	switch and speaker cables because cable length might be > 3m.
IEC 61000-4-5 (surges)	N/A; all SIP/SOP cables not directly connected to outdoor cables.
IEC 61000-4-6 (cond. RF)	Only applicable for patient headsets, patient client switch and speaker cables because cable length might be > 3m.

B.3.2 Maximum permissible Cable Lengths of Accessories

Accessory, Transducer	Maximum cable length
Power Supply (low voltage side)	1,8 meters
USB cable	3 meters
REM probes Client response switch Air conductor headsets like TDH39, DD45, DD450, HDA300 Bone conductor headsets like B71	2,5 meters (In combination with extension cable 91.0704 prolongable up to 5,5 meters)
Insert headsets like EAR-3A, ER-3C	2 meters (In combination with extension cable 91.0704 prolongable up to 5,5 meters)
Free field calibration microphone	3 meters
Table microphone (Talk back microphone)	2,5 meters
Headset with microphone (Monitor headset)	2,5 meters
Loudspeaker LS01	5 meters
RECD Speaker LS Mini	2,5 meters

B.4 Pin Assignments Table

Primus Fitting Unit

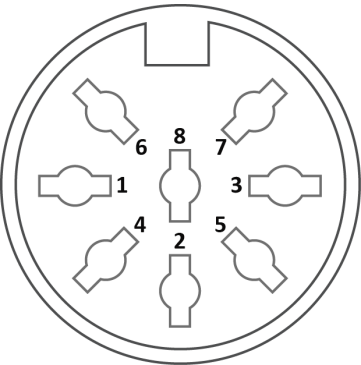
Connector		Air Conductor 1, 2, 3	Bone Conductor
<p>Standard DIN Connector 8 pins</p>  <p>female</p>		1. Ground	1. Output
		2. Data Up/Down-load	2. Data Up/Download
		3. Ground	3. Not Connected
		4. Optional Microphone Input	4. Not Connected
		5. Plug Detect	5. Plug Detect
		6. Left Channel Output	6. Ground
		7. Right Channel Output	7. Not Connected
		8. Ground	8. Ground
Option ^{*2*3}	Primus Probe ^{*1} /Real Ear Probe ^{*2*3}	Client Response	
1. Secondary Microphone Input	1. Ground	1. Not Connected	
2. Data Up/Download	2. Data Up/Download	2. Logic Input (High/Low)	
3. Ground	3. Ground	3. Not Connected	
4. Primary Microphone Input	4. Reference Microphone Input, Left	4. +3.3 Vdc	
5. Plug Detect	5. Reference Microphone Input, Right	5. Plug Detect	
6. Speaker Output, positive	6. Probe Microphone Input, Left	6. Control Clock	
7. Speaker Output, negative	7. Probe Microphone Input, Right	7. Control Data	
8. Ground	8. Ground	8. Ground	

Connector		Client^{*1*2}/Demo^{*3} Headset	Free Field: Left/Right, Rear and Sub/Mid^{*1*2} Free Field: Line out 1, Line out 2 Line out 3^{*3}
3.5 mm TRS socket (mini-jack) 		1. Left Channel Output	1. Channel 1,3,5 Output
		2. Right Channel Output	2. Channel 2,4,6 Output
		3. Ground	3. Ground
Monitor Headset	Operator Micro- phone Left	Operator Micro- phone Right	Talk Back Microphone
1. Left Channel Output	1. Input	1. Input	1. Input
2. Right Channel Output	2. Not Connected	2. Not Connected	2. Not Connected
3. Ground	3. Ground	3. Ground	3. Ground

Power supply: DC POWER JACK 	1. +15 Vdc, 2A max (Center)
	2. Ground (Sleeve)

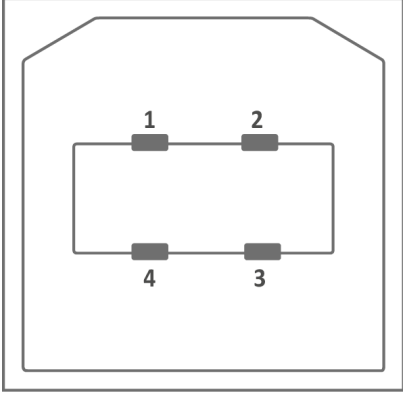
<p style="text-align: center;">USB: Type B connector</p> 	<p>1. 5 Vdc, 0.5A max</p> <p>2. Data -</p> <p>3. Data +</p> <p>4. Ground</p>
--	--

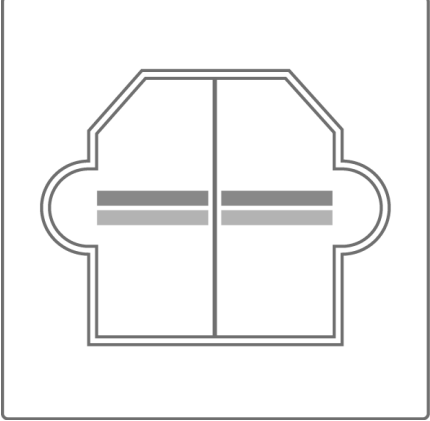
	<p>SPDIF: Toslink optical transmitter^{*3}</p>
--	--

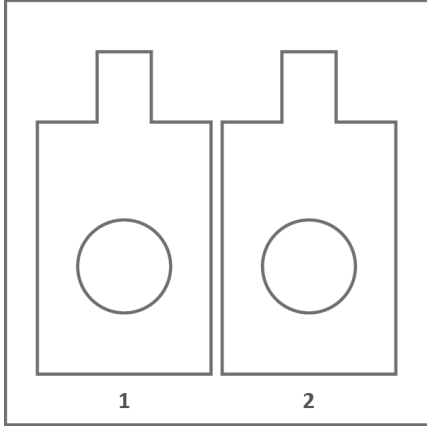
<p>Speaker Output Right, Mid, Left</p> 	<p>1. Positive</p>
	<p>2. Negative</p>

*1 This plug is only available in the PFU.

*2 This plug is only available in the PFU+.

*3 This plug is only available in the Primus Pro.

2000-1 Fitting Unit

8-pin Mini-Din Connector Front View	Pin	Connector				
		AC1, AC2	BC	Client Resp.	Option	REM Probe
	1	Plug detect	Plug detect	Plug detect	Plug detect	Signal Ref. Mic. R
	2	Ground	Ground	+3.3VDC	Signal Coupler Mic.	Signal Ref. Mic. L
	3	Signal R	Signal	I2C Data	RECD Speaker +	Signal Tube Mic. R
	4	Data	Data	Pat. Signal	Data	Data
	5	Signal L	Signal	I2S Clock	RECD Speaker -	Signal Tube Mic. L
	6	Ground	Sig.	Ground	Ground	Ground

		R	Ground		Ref. Mic.	Tube Mic. R
	7	Ground	Ground	Ground	Ground Coupl. Mic.	Ground Ref. Mic. L&R
	8	Ground L	Sig. Ground	Ground	Signal Ref. Mic.	Ground Tube Mic. L

3.5 mm Stereo Jack	Pin	Connector	
			Monitor Headset, Line Out
	1 (Tip)	Signal Output Left	Signal Input (Bias Voltage)
	2 (Ring)	Signal Output Right	Not connected
	3 (Sleeve)	Ground	Ground

Power Supply, DC Power Jack	Pin	Signal
	Center Pin	+15VDC / max. 2A
	Sleeve	Ground

Speaker, Left and Right	Pin	Signal
-------------------------	-----	--------

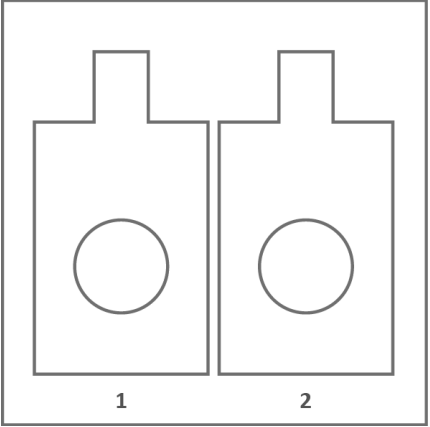
 <p>The diagram shows two identical battery cells side-by-side, labeled '1' and '2'. Each cell is a rectangle with a smaller rectangle protruding from the top center and a circle in the lower half.</p>	1	Positive Terminal
	2	Negative Terminal

Appendix C

C.1 Minimum Requirements (for Software Installation)

C.1.1 PC specifications for the connected operator PC

	Minimum requirements	Recommended requirements
Processor/clock speed	2 GHz	2 GHz (or higher) multi-core
System RAM	2 GB	4 GB or more
Free hard drive space	2 GB	2 GB
Operating System*	Windows 10 and Windows 10 Anniversary Update	Windows 10 and Windows 10 Anniversary Update Windows 11
Screen Resolution	1280 x 1024	1600 x 1200
Graphics Card	XVGA	Dual monitor output
CD Drive	Required if speech test CD´s are used.	Required if speech test CD´s are used.
Connection of Fitting System to PC	USB connector 2.0 or higher	USB connector 2.0 or higher
Connection of HIT System to PC (optional)	USB connector 2.0** or higher	USB connector 2.0** or higher

* Your OS must be up to date. All Windows updates must be installed.

** If a USB hub must be used in order to connect both units, a hub with power supply is recommended.